

XPOWER DC INVERTER



TOTALINE

For more details, please contact our Carrier India sales office:

Factory & Corporate Office: Carrier Airconditioning & Refrigeration Ltd, Kherki Daula Post, Narsingpur, Gurgaon 122004, Tel: 0124-4825500
Sales Offices:- Delhi/NCR: 0124-4707311/4707333 Ghaziabad: 0120-4183260 Lucknow: 0522-4158703/4158710 Chandigarh: 0172-5007549/
5007550 Jaipur: 0141-5113444/5113999 Indore: 0731-4070378 Mumbai: 022-61700700 Ahmedabad: 079-44820400 Pune: 020-67045100 Kolkata:
033-40524354 Chennai: 044-66448888 Bangalore: 080-43442000 Hyderabad: 040-41100222 Cochin: 0484-4029001/0

CIN: U74999HR1992FLC036104/ Website: www.carrierindia.com



This catalogue provides certain general information and is intended for general guidance only and Carrier is not liable for any damage arising out of the use of the catalogue.
The Manufacturer reserves the right to change any product specification without prior notice.
All Proprietary Rights Reserved Carrier

July 2015

VRF System



Developed to facilitate more flexible system design for big-sized buildings

Carrier proudly introduces the X-Power VRF product, which is flexibly designed for a variety of applications/ occasions. Offering a higher capacity up to 72HP increments, it caters to all needs and requirements. It also incorporates numerous outstanding features, a range of large capacity outdoor units and indoor units, longer level difference and actual piping length and high external static pressure. The X-Power VRF product provides a flexible design and easy installation in big-sized and high-rise building for wide application.

Contents

- 03 XPower VRF V4+K
- 23 XPower VRF V4+I Individual
- 26 XPower VRF V4+S Full DC Inverter
- 34 XPower Mini VRF
- 48 XPower Flexi Indoor Units
- 110 Control Devices
- 111 Control Systems
- 122 Accessories



XPOWER VRF V4+ K

Flexible Wide Application Range

Flexi Modular Outdoor Units Lineup for Wide Range of Outdoor Units

- The Outdoor units capacity range is from 8HP up to 72HP in 2HP increment. Maximum 4 (four) outdoor units can be connected in one VRF System With maximum 64 indoor units with capacity up to 130% of the total outdoor units capacity.
- One Single Modular VRF DC Inverter Outdoor Unit

One Single Modular VRF DC Inverter Outdoor Unit can be connected with maximum quantity of 29 indoor units as per the below figure and table



One Single Modular DC Inverter Outdoor Unit

Outdoor Unit Capacity (HP)	8	10	12	14	16	18	Indoor Units
8	●						13
10		●					16
12			●				20
14				●			23
16					●		26
18						●	29

- Two Modular VRF DC Inverter Outdoor Units Combination

Two Modular VRF DC Inverter Outdoor Units can be connected with maximum quantity of 59 indoor units as per the below figure and table



Two Modular DC Inverter Outdoor Units Combination

Outdoor Unit Capacity (HP)	18	20	22	24	26	28	30	32	34	36	Indoor Units
18	●	●									20
20		●●									33
22		●	●								36
24		●		●							39
26		●			●						43
28		●			●●	●			●		46
30					●	●	●				50
32						●		●			53
34							●	●	●		56
36									●●		59

Flexible Wide Application Range

Flexi Modular Outdoor Units Lineup for Wide Range of Outdoor Units

Three Modular VRF DC Inverter Outdoor Units Combination

Three Modular VRF DC Inverter Outdoor Units can be connected with maximum quantity of 64 indoor units as per the below figure and table



Three Modular DC Inverter Outdoor Units Combination

Outdoor Unit Capacity (HP)	Indoor Unit Capacity (HP)						Total Indoor Units
	38	40	42	44	46	48	
38	••					•	63
40	•		•		•		64
42	•			••			64
44	•			•		•	64
46	•				••		64
48			•	•		•	64
50			•		••		64
52				•	••		64
54					•••		64

Four Modular VRF DC Inverter Outdoor Units Combination

Four Modular VRF DC Inverter Outdoor Units can be connected with maximum quantity of 64 indoor units as per the below figure and table



Four Modular DC Inverter Outdoor Units Combination

Outdoor Unit Capacity (HP)	Indoor Unit Capacity (HP)						Total Indoor Units
	38	40	42	44	46	48	
56			••			••	64
58			•		•	•	64
60			•		•	••	64
62			•		•	••	64
64			•			•••	64
66				•	•	••	64
68				•		•••	64
70						•••	64
72						••••	64

Flexible Wide Application Range

Wide Operation Range

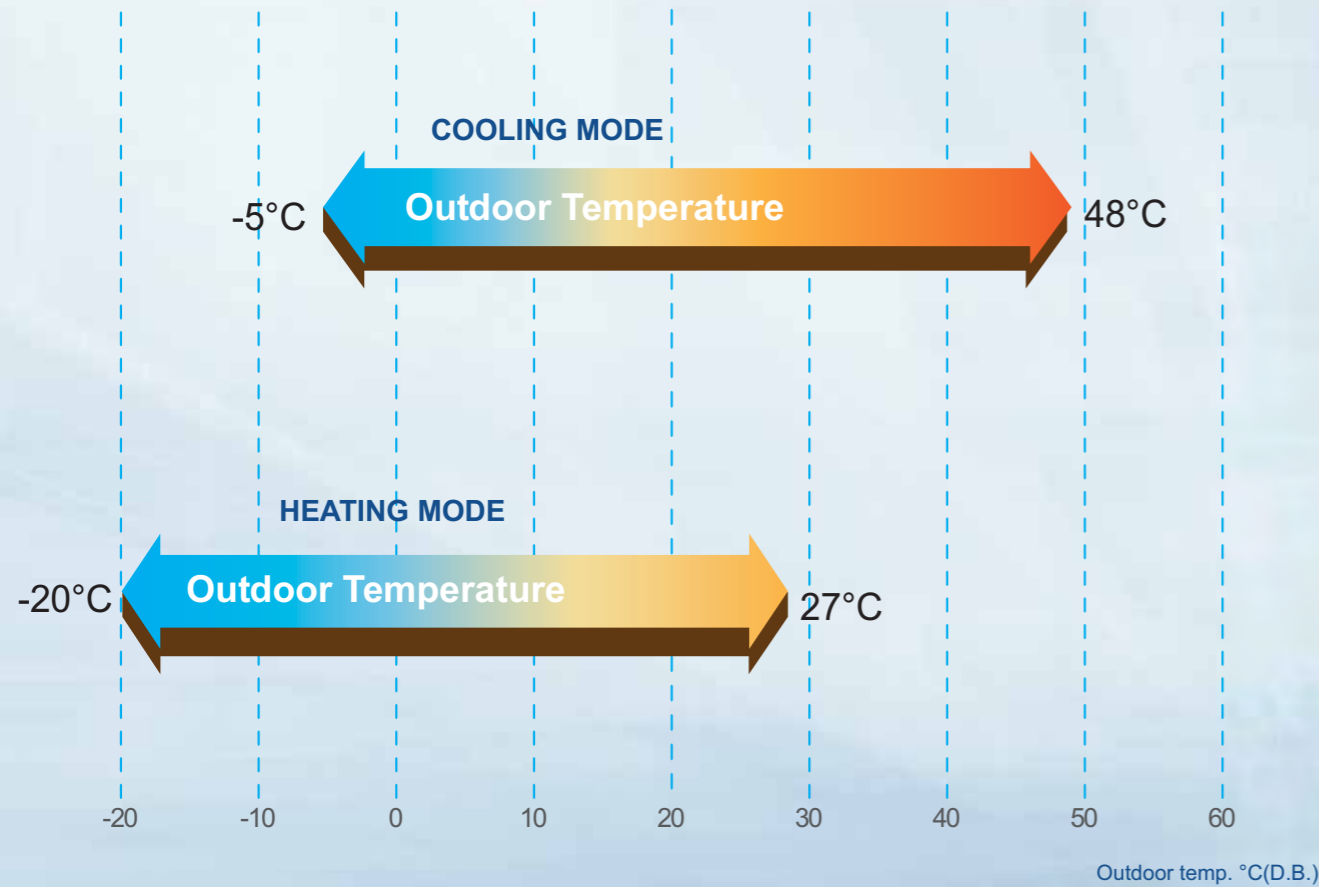

Extra High Static Pressure – Max. 40Pa and Air Volume Increased by 10%

- High-static pressure propeller and optimized fan guard can adapt to various installation environments.
- Carrier now offers up to 40 Pa* external static pressure units for customized applications.
- Standard 0-20Pa function is equipped by default.



* You need to consult Carrier sales team if you require over 40Pa external static pressure .

Flexible Long Piping Length

VRF DC Inverter system provides an actual total piping length of 1000 m, a maximum of 110 m between outdoor and indoor units.

The height difference between outdoor units can be up to 8 m

These generous allowances facilitate an extensive array of system design making VRF DC Inverter perfect for large projects.

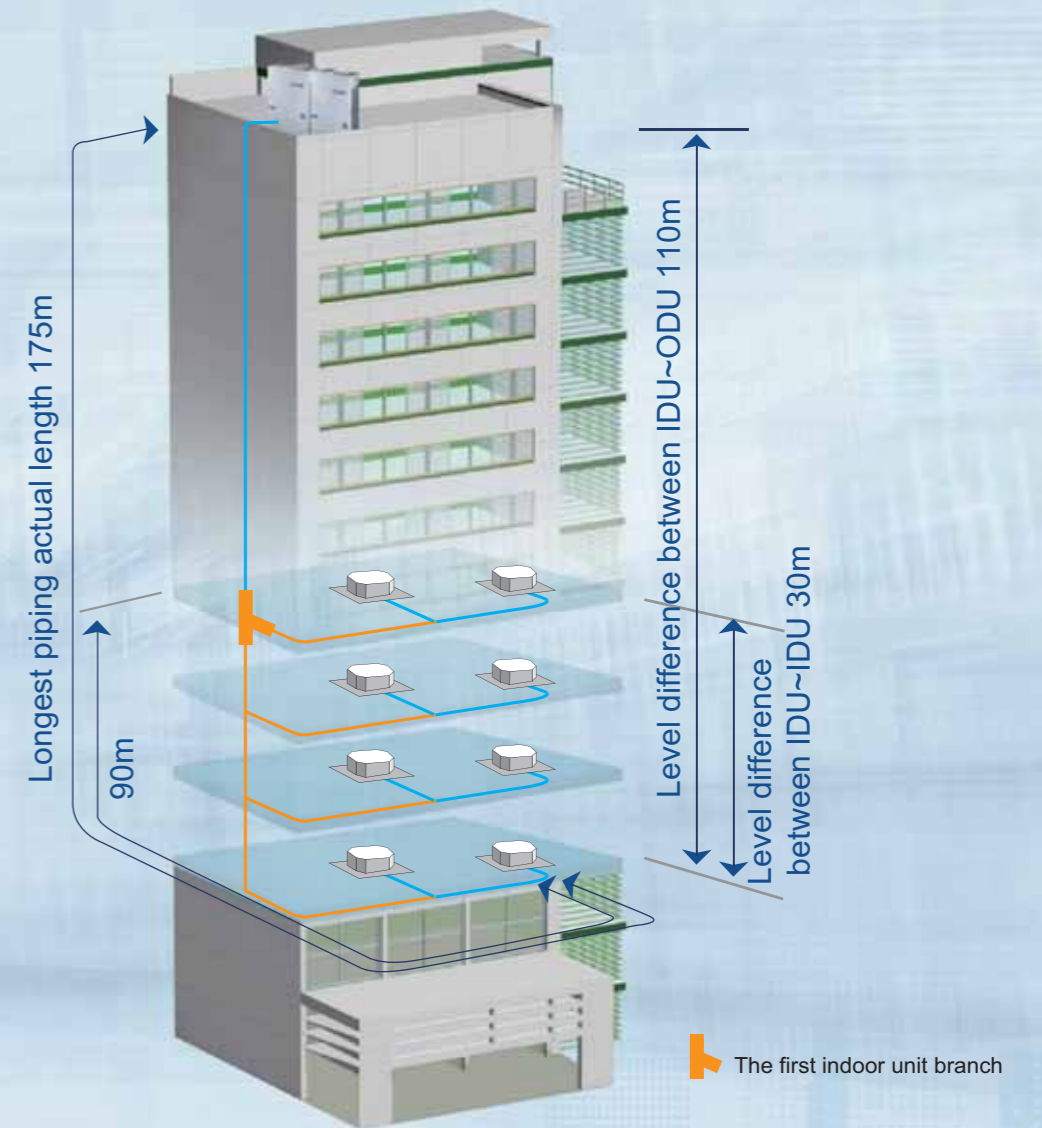

		Permitted value	
Piping length	Total piping length* ¹ (Actual)	1000m	
	Longest piping (L)	Actual length	175m
		Equivalent length	200m
Piping (The farthest IDU from the first Indoor unit branch) equivalent length		40m/90m* ²	
Level difference	Level difference between IDU~ODU	Outdoor unit up	70m
		Outdoor unit down	110m
	Level difference between IDU~IDU		30m

*¹ Total pipe length is equal to two times orange pipe length plus blue pipe length.
*² When the farthest pipe length is more than 40m. It needs to meet the specific conditions according to the installation manual.

Advanced Technologies

DC Inverter Scroll Compressor

For VRF ECO DC Inverter – Modular Outdoor Units

- 8HP and 10HP models are equipped with one DC inverter compressor
- 12, 14, 16, 18 HP models are equipped with one DC inverter compressor and one fixed frequency compressor.

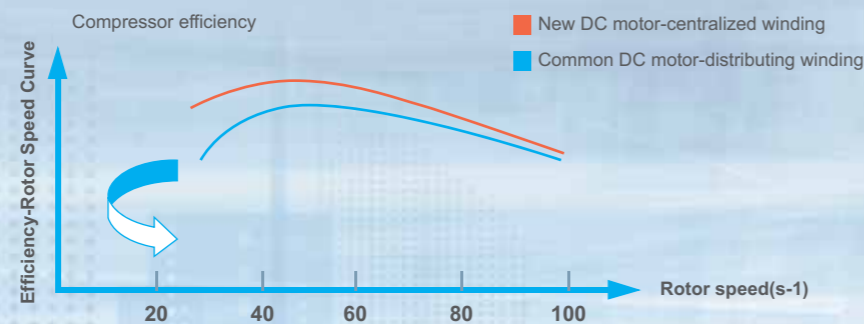
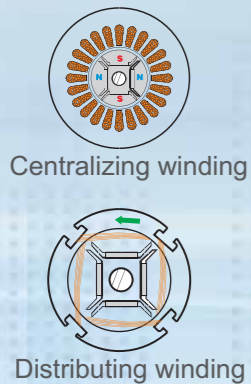
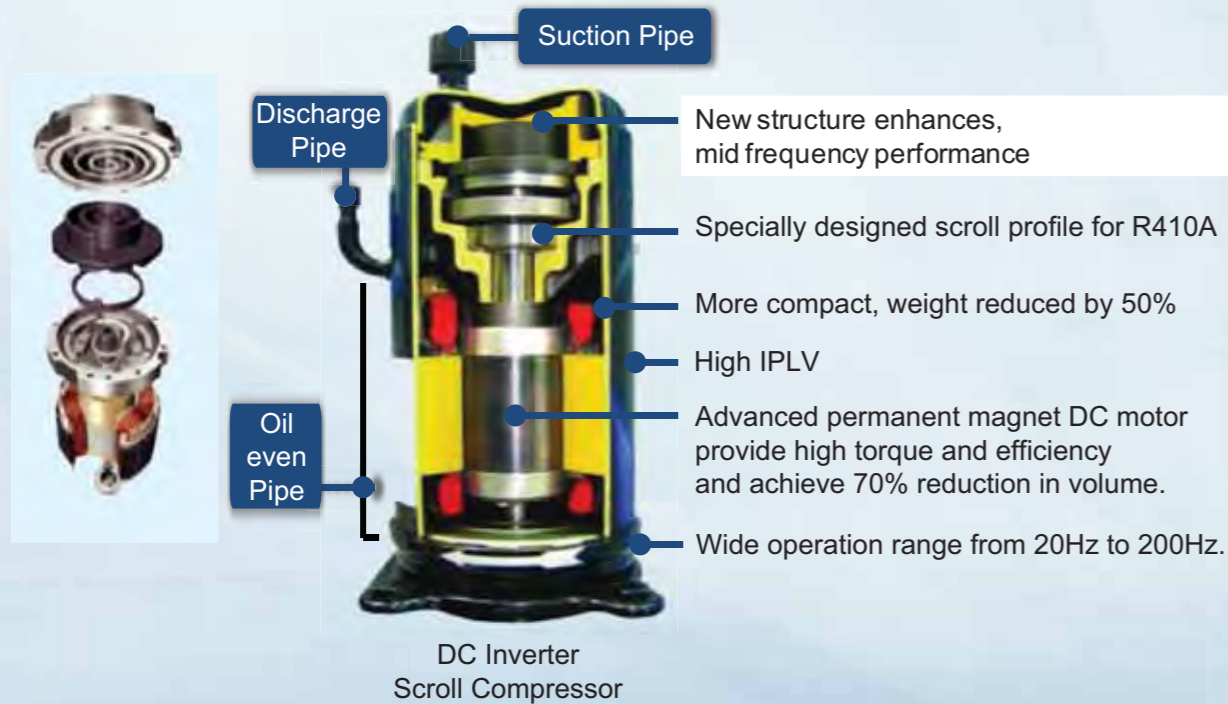

Smooth 180° sine wave DC Inverter

By adoption of the 180° SineWave Inverter which smooths the rotation of the compressor motor, and improves compressor efficiency sharply than traditional sawtooth wave.

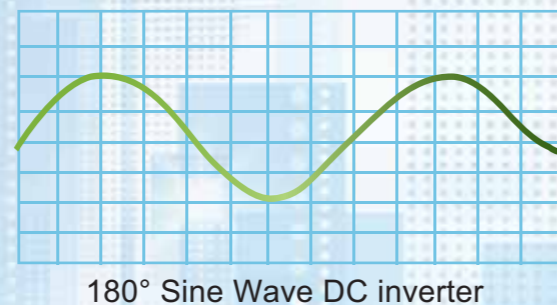
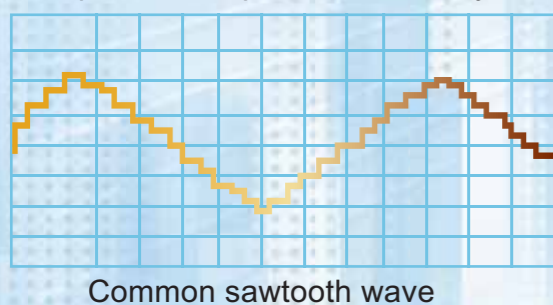

High Efficiency and Super Quiet DC Fan Motor

For VRF ECO DC Inverter – Modular Outdoor Units

- 8HP and 10HP models are equipped with one DC fan motor
- 12, 14, 16, 18 HP models are equipped with two DC fan motor.

According to the running load and pressure, it controls the speed of DC fan motor to achieve the minimum power consumption.

- Used across entire range of models (from 8 to 72 HP).
- Efficiency improvement up to 45% especially at low speed.
- Wide speed adjustment with 18 steps vector control.

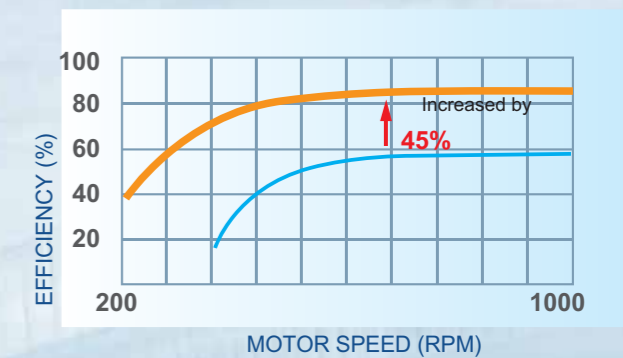
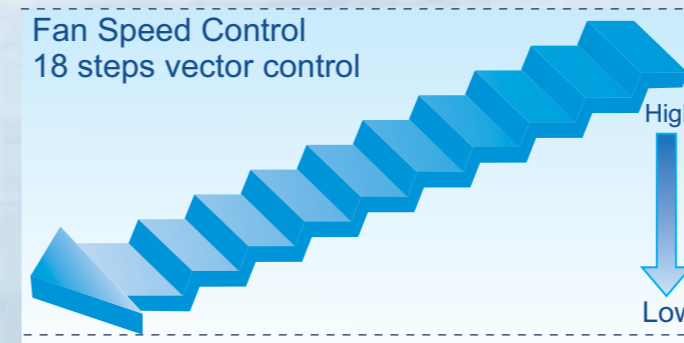
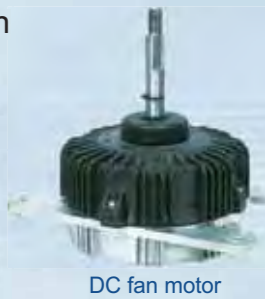

High Efficiency / Super Quiet Fan Housing and Outlet Grille

- Optimum design of fan housing and outlet grille for minimum airflow resistance, maximum air flow, minimum sound level and minimum vibrations.
- Efficient Air Management System (AMS) with uniform air circulation over the complete coil surface at low velocity for maximum efficiency and minimum sound level.



High Efficiency and Super Quiet Outdoor Fan (s)

Optimum design of 3-dimensional turbo fan with patent aerodynamic new profile design of fan blades with sharp edge and little curve bigger diameter for minimum airflow resistance, maximum airflow, minimum sound and minimum vibrations.

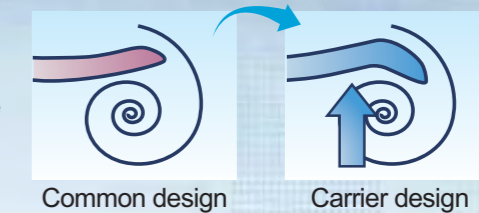

New Fan Arrangement Technology for Sound Reduction

Capacity	8 / 10 HP	12 / 14 / 16 / 18 HP
Fan Qty.	1	1 + 1

High Efficiency

High EER / High COP Values

VRF ECO DC Inverter Series with all high efficiency DC Inverter scroll compressors all, DC motors and high efficiency heat exchanger, achieve the world's Top Class energy efficiency. Cooling EER up to 4.29 and Heating COP up to 4.39 in the 8HP category.

EER

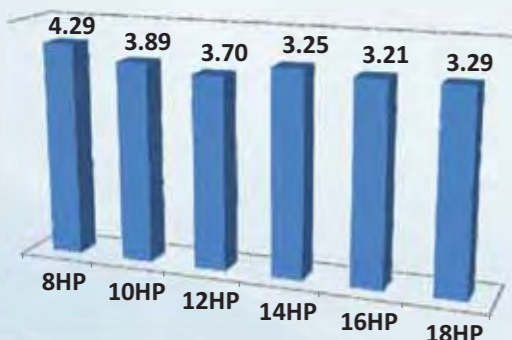

COP

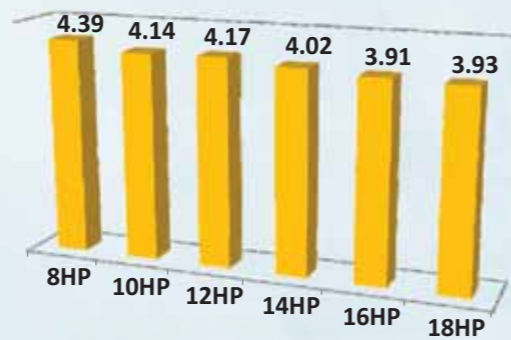

Multi solenoid valves control technology

Multi solenoid valves control technology and double EEV control technology in one VRF system. All the solenoid valves equipped in the unit ensure temperature-control precisely, system running steadily and economic to provide a comfortable environment.

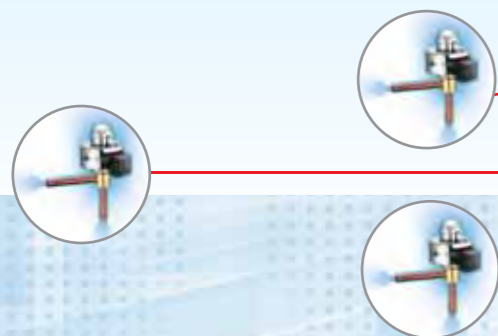

High Efficiency Heat Exchanger

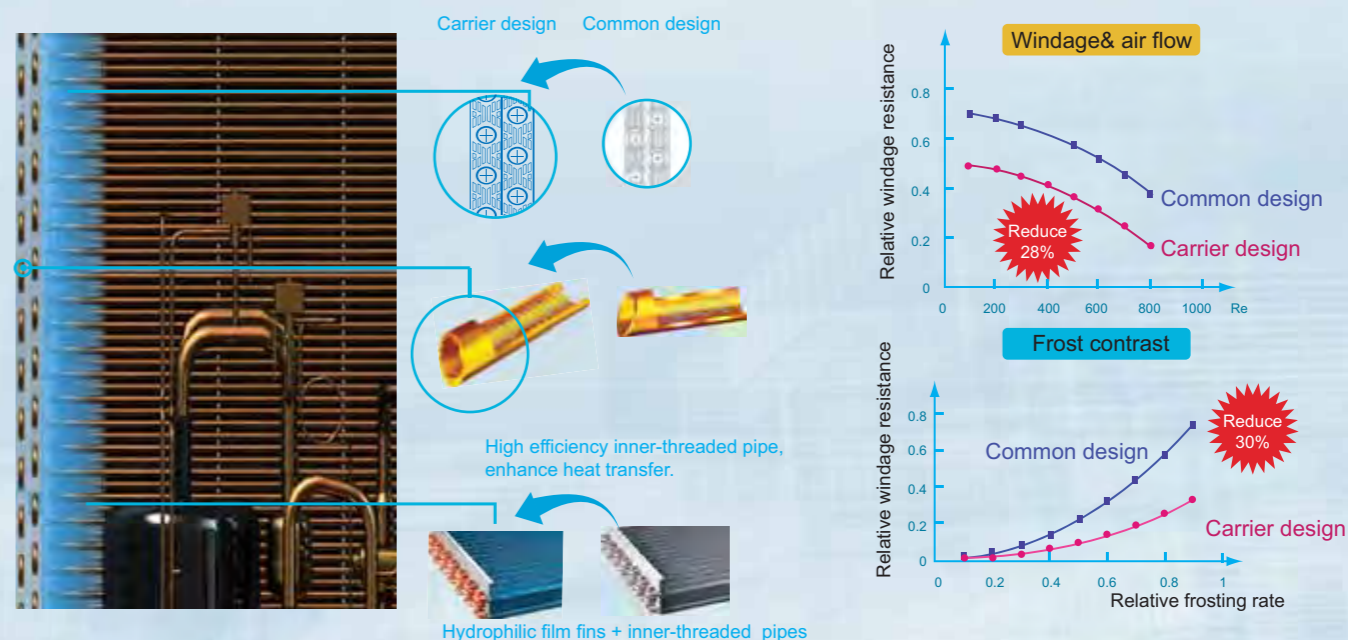

- The new designed window fins enlarge the heat-transfer area, decrease the air resistance, save more power and enhance heat transfer performance in cooling and heating.
- Hydrophilic aluminum fins and inner-groove copper tubes optimize heat transfer efficiency.

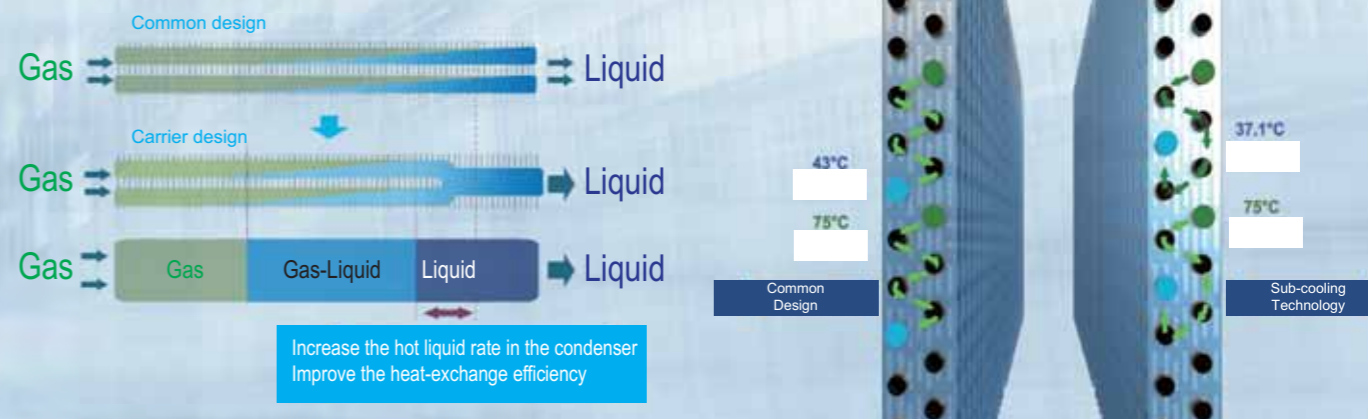

- Innovative designed high efficiency heat exchanger, which can reach up to 12°C subcooling degree, reduces the system resistance and improves reliability.
- When the outdoor temperature is 35°C, the refrigerant can be cooled down to 37.1°C, thus achieving high heat-transfer efficiency with only 2.1°C temperature difference.

High pressure sensor

- Controls the discharge pressure of the compressor and to control the fan speed.



Always test the system pressure



Every 20 seconds, compare the system pressure and the best pressure to adjust DC fan motor speed timely.

High Efficiency VRF DC Inverter Outdoor Unit

High efficiency & super quiet Fan housing and outlet grill



High efficiency & super quiet Outdoor fan (s)



High efficiency & super quiet DC fan motor



High efficiency 180°sine-wave DC inverter control For compressor motor

For smooth rotation of compressor motor and high efficiency of compressor motor.



High efficiency outdoor coil



High efficiency & super quiet DC Inverter Scroll compressor



High efficiency & super quiet Fixed frequency Scroll compressor(s)

Only for VRF ECO DC Inverter outdoor unit.

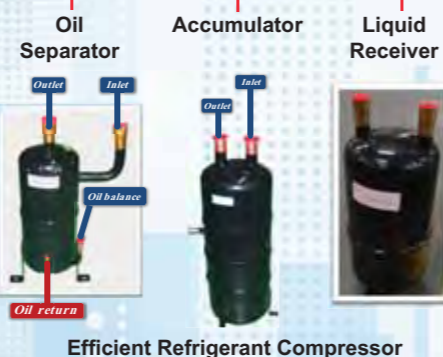

Night Silent Operation Mode For Super Silent Operation

- Carrier Night Silent Mode feature which is easily set on the main board allows the unit to be set to various time options during Non Peak and Peak operation time optimizing the units sound output.
- Super silent operation mode can reduce sound level further, minimum 45 dB (A).
- Night silent operation will be activated X hours after the peak temperature during daytime, and it will go back to normal operation after Y hours.

-Model 1→X: 6 hours, Y: 10 hours
-Model 3→X: 6 hours, Y: 12 hours

-Model 2→X: 8 hours, Y: 10 hours
-Model 4→X: 8 hours, Y: 8 hours

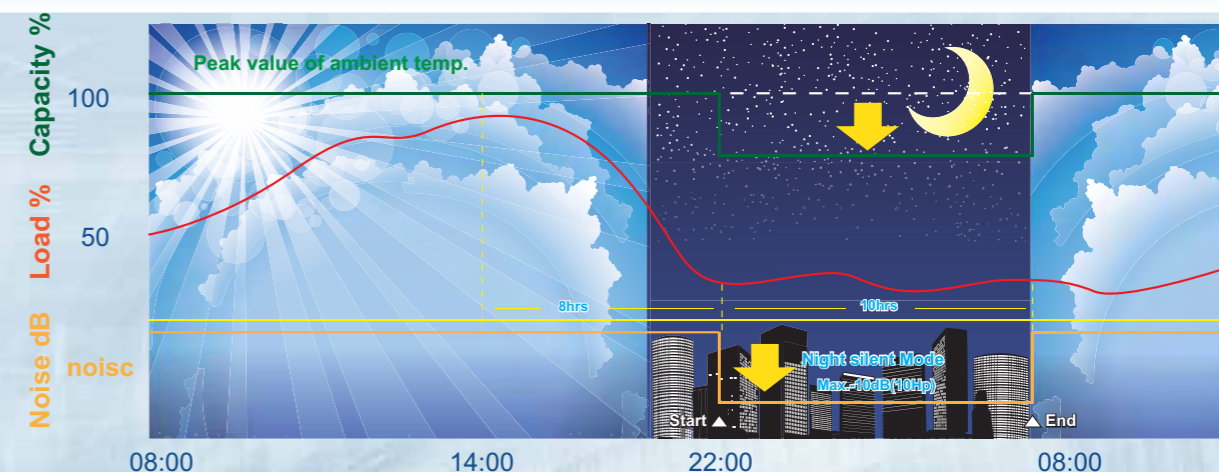

Notes: This function can be activated by setting at site. Temperature(load) curve shown in the graph is just an example.

Intelligent Defrost Extends Comfortable Time & Increase Heat Capacity

Test Drawing: Intelligent defrost Heating 85min, defrost 4min

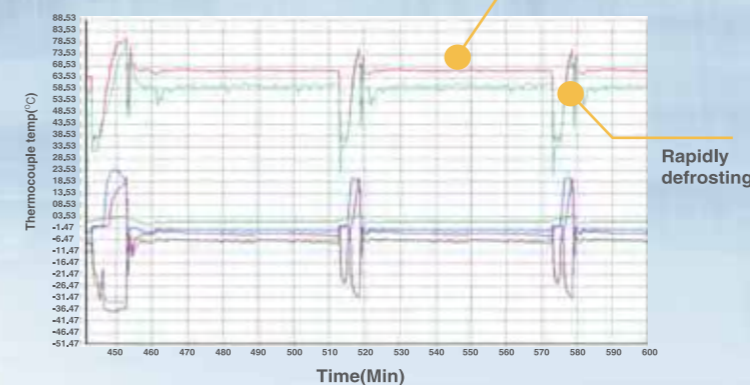

Test Drawing: Common Defrost Heating 50min, defrost 10min

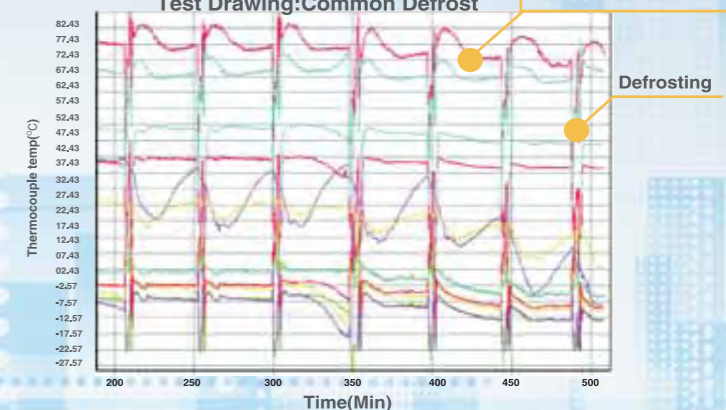

High Reliability

Duty Cycling Function

■ In one combination of VRF ECO DC inverter - modular outdoor units, any outdoor unit can run as the master outdoor unit to equalize the service life of all outdoor units.

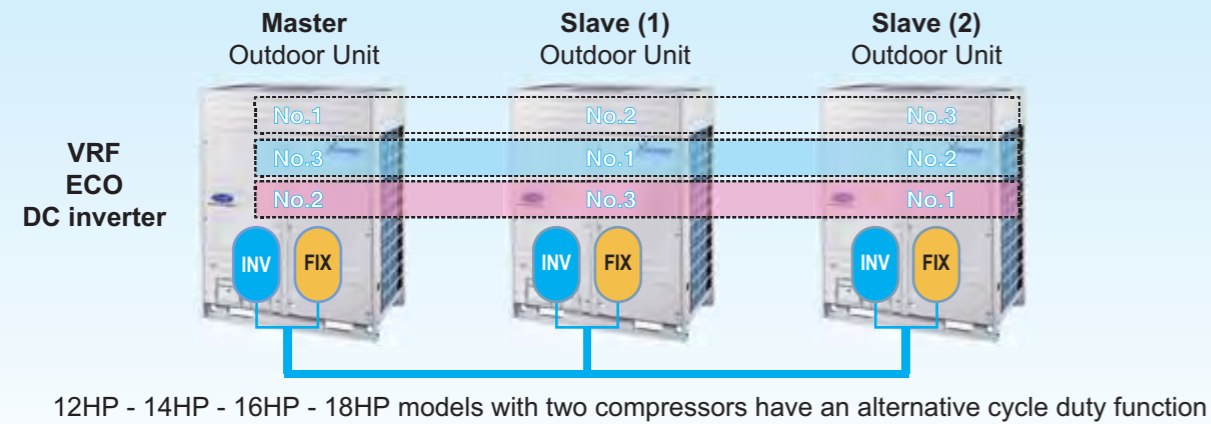

High efficiency oil balance and oil return technology

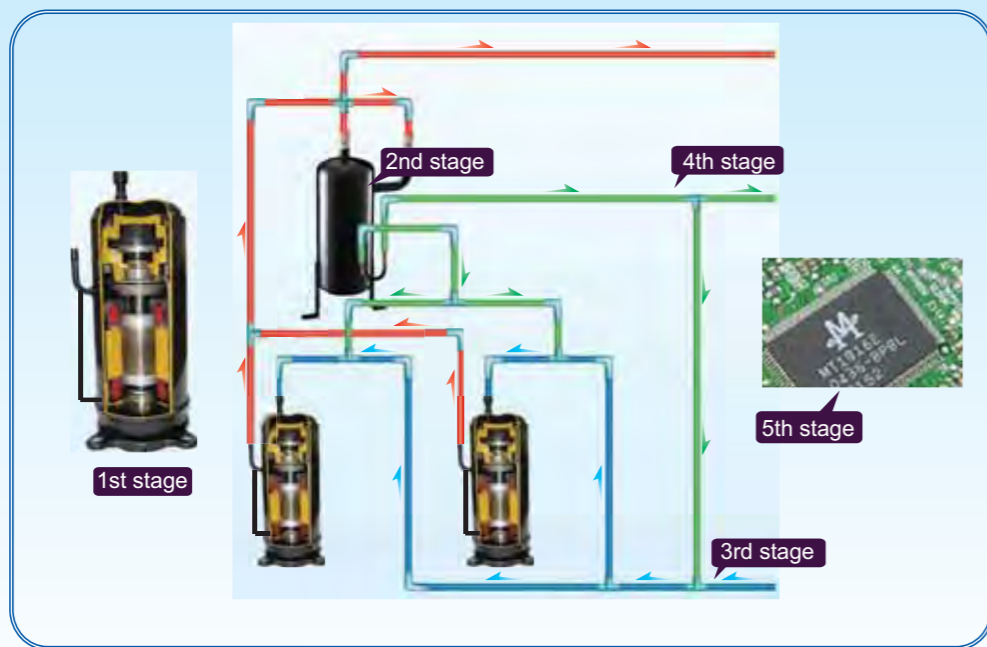

5 stage oil control technology ensures every outdoor unit & compressor's oil always keep in the safe level, completely solve the compressor oil lack problem.

- 1st stage: compressor internal oil separate
- 2nd stage: high efficiency oil separator (separation efficiency up to 99%)
- 3rd stage: oil balance technology between compressors
- 4th stage: oil balance technology between modules
- 5th stage: intelligent system oil return program

Back-up Function

In one combination of VRF ECO DC inverter – modular outdoor units, when the master outdoor unit failed, any single slave outdoor unit can be set as the master unit, then the remaining outdoor units can keep on working. This can be set at field by DIP switch located on the main board of electrical control box of outdoor unit.

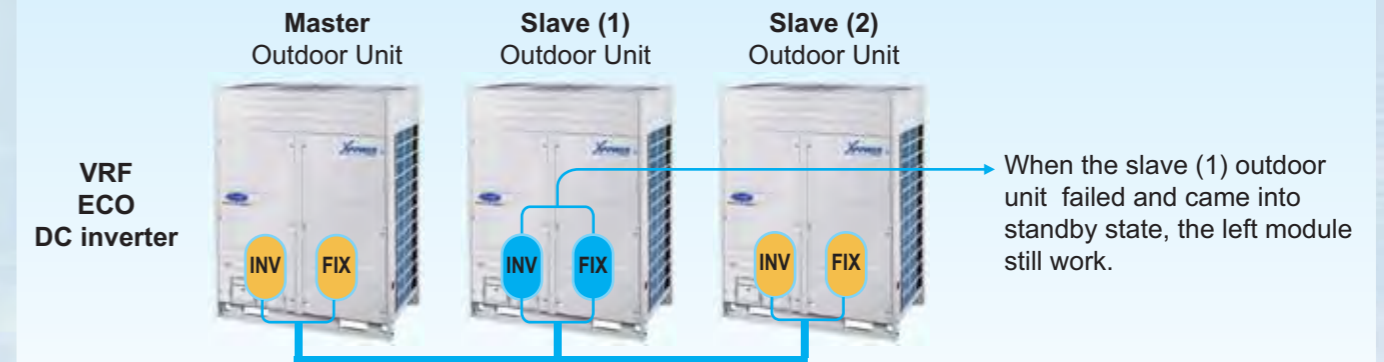

Indoor Unit Quantity Monitoring

The quantity of indoor units should be exactly set on the outdoor main board, once some indoor units miscommunicate with outdoor units during system running, the outdoor units will stop and display the fault code "H7". This can prevent compressor from liquid hammer caused by dropped indoor units with EXV unclosed.

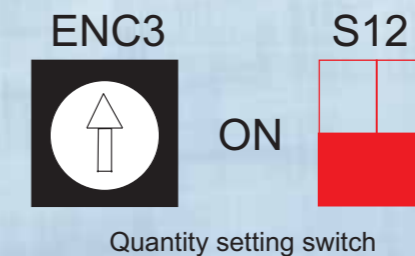

Easy Installation, Service and Maintenance

Compact Design for Effective Use of Space

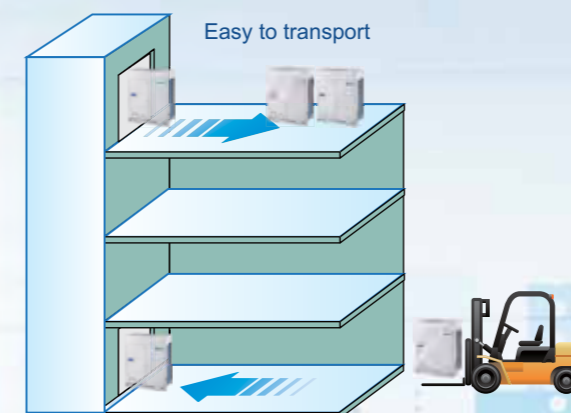

VRF DC Inverter system's indoor and outdoor units are easy in installation, service and maintenance.

Compact size and light weight design minimizes the installation footprint, reduces the installation floor load, and is easier for transportation. For some projects the units can even be transported through the elevator or forklift, reduce access problem at the jobsite and reduce time and labor.

Easy Service and Maintenance



Reserved checking window on electric control box for convenient spot checking and status enquiry.

88 88

Self-diagnosis function helps service engineers to locate faults quickly and easily.

Compressor is located near the door, which simplifies checks and enables valve or compressor parts to be replaced easily.



Simple Signal Line Connection

Installation is easier as communication wiring can be shared by indoor & outdoor units. It's easy for the user to retrofit the existing system with a centralized control by simply connecting to the outdoor units.

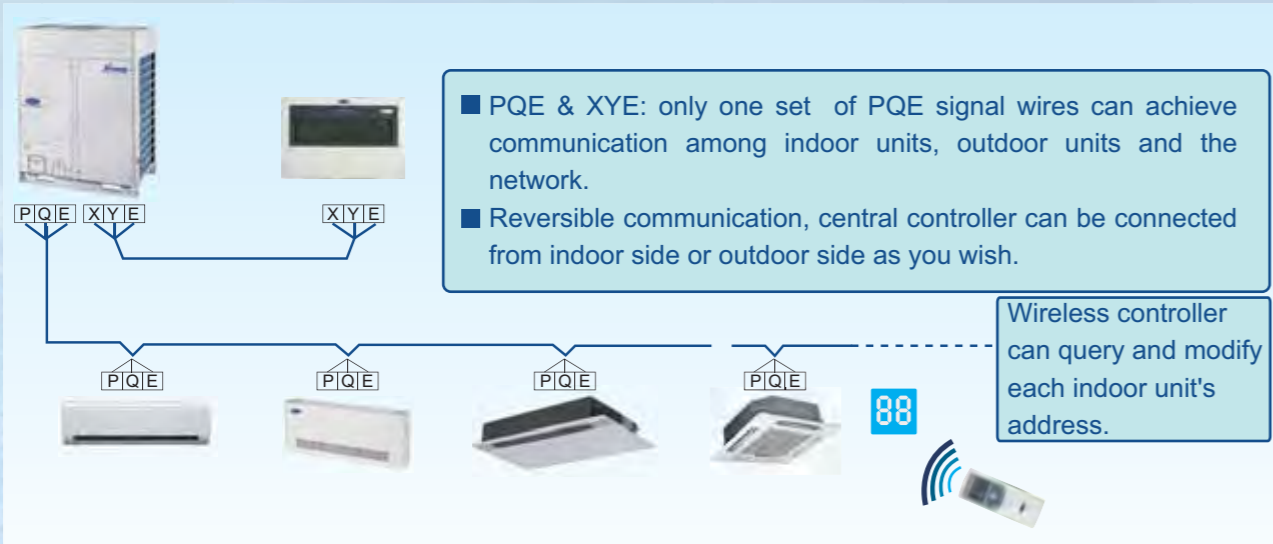

Auto Addressing of Indoor Units

Through Wireless Remote Control

Wireless remote control can query and modify each indoor unit's address.



Through Outdoor Unit

Outdoor unit can automatically distribute the addresses to indoor units.



Various locking modes enhance convenience for users

In VIP priority or vote priority mode, the address of the VIP unit should be set as 63, if there is no 63 unit, it will respond to vote priority.



MODULAR OUTDOOR UNITS – V4+K



8 HP - 10 HP



12 HP



14 HP - 16 HP



18 HP

■ Technical specifications

Outdoor Unit Model		38VR008H1190K1	38VR010H1190K1	38VR012H1190K1	
Power supply		V-Ph-Hz 380 ~ 415 - 3 ~ 50			
Cooling(*1)	Capacity	kW	25.2	28	33.5
		Btu/h	85,982	95,536	114,302
	Input	kW	5.9	7.2	9.1
		EER	W/W	4.29	3.89
Heating(*1)	Capacity	kW	27	31.5	37.5
		Btu/h	92,124	107,478	127,950
	Input	kW	6.15	7.6	9.0
		COP	W/W	4.39	4.14
Compressor	Quantity	1	1	1 + 1	
	Type	DC Inverter	DC Inverter	DC Inverter + Fixed Frequency	
Outdoor Fan Motor	Quantity	1	1	1 + 1	
Outdoor air flow		m3/h	11500	11500	15100
Outdoor sound pressure(*2)		dB(A)	57	57	59
Outdoor unit	Dimension(W*H*D)	mm	960*1615*765	960*1615*765	1250*1615*765
	Packing (W*H*D)	mm	1025*1790*830	1025*1790*830	1305*1790*825
	Net/Gross weight	Kg	200/215	200/215	268/288
Refrigerant Piping Lines (*3)	Gas	ø 25.4	ø 25.4	ø 31.8	
	Liquid	ø 12.7	ø 12.7	ø 15.9	

1.Nominal conditions

	Indoor	Outdoor	Pipe length	Level difference
Cooling	27°C DB (80.6°F), 19°C WB (60°F)	35°C DB (95°F)	7.5m	0m
Heating	20°C DB (68°F), 15°C WB (44.6°F)	7°C DB (42.8°F)	7.5m	0m

2.Sound level: Anechoic chamber conversion value, measured at a position 1m in front of the unit and 1.5m above the floor.

3.Refrigerant pipe dim.listed here only for when the total equivalent length < 90m. For the data when total equivalent length 90 m please refer to technical manual.

■ Technical specifications

Outdoor Unit Model		38VR014H1190K1	38VR016H1190K1	38VR018H1190K1	
Power supply		V-Ph-Hz 380 ~ 415 - 3 ~ 50			
Cooling(*1)	Capacity	kW	40	45	50
		Btu/h	136,480	153,540	170,600
	Input	kW	12.3	14.0	15.2
		EER	W/W	3.25	3.21
Heating(*1)	Capacity	kW	45	50	56
		Btu/h	153,540	170,600	191,072
	Input	kW	11.2	12.8	14.3
		COP	W/W	4.02	3.91
Compressor	Quantity	1 + 1	1 + 1	1 + 1	
	Type	DC Inverter + Fixed Frequency	DC Inverter + Fixed Frequency	DC Inverter + Fixed Frequency	
Outdoor Fan Motor	Quantity	1 + 1	1 + 1	1 + 1	
Outdoor air flow		m3/h	15100	15100	15250
Outdoor sound pressure(*2)		dB(A)	60	60	61
Outdoor unit	Dimension(W*H*D)	mm	1250*1615*765	1250*1615*765	1250*1615*765
	Packing (W*H*D)	mm	1305*1790*825	1305*1790*825	1305*1790*820
	Net/Gross weight	Kg	280/300	280/300	300/320
Refrigerant Piping Lines (*3)	Gas	ø 31.8	ø 31.8	ø 31.8	
	Liquid	ø 15.9	ø 15.9	ø 19.1	

1.Nominal conditions

	Indoor	Outdoor	Pipe length	Level difference
Cooling	27°C DB (80.6°F), 19°C WB (60°F)	35°C DB (95°F)	7.5m	0m
Heating	20°C DB (68°F), 15°C WB (44.6°F)	7°C DB (42.8°F)	7.5m	0m

2.Sound level: Anechoic chamber conversion value, measured at a position 1m in front of the unit and 1.5m above the floor.

3.Refrigerant pipe dim.listed here only for when the total equivalent length < 90m. For the data when total equivalent length 90 m please refer to technical manual.

Outdoor Unit dimensions (Unit : mm)

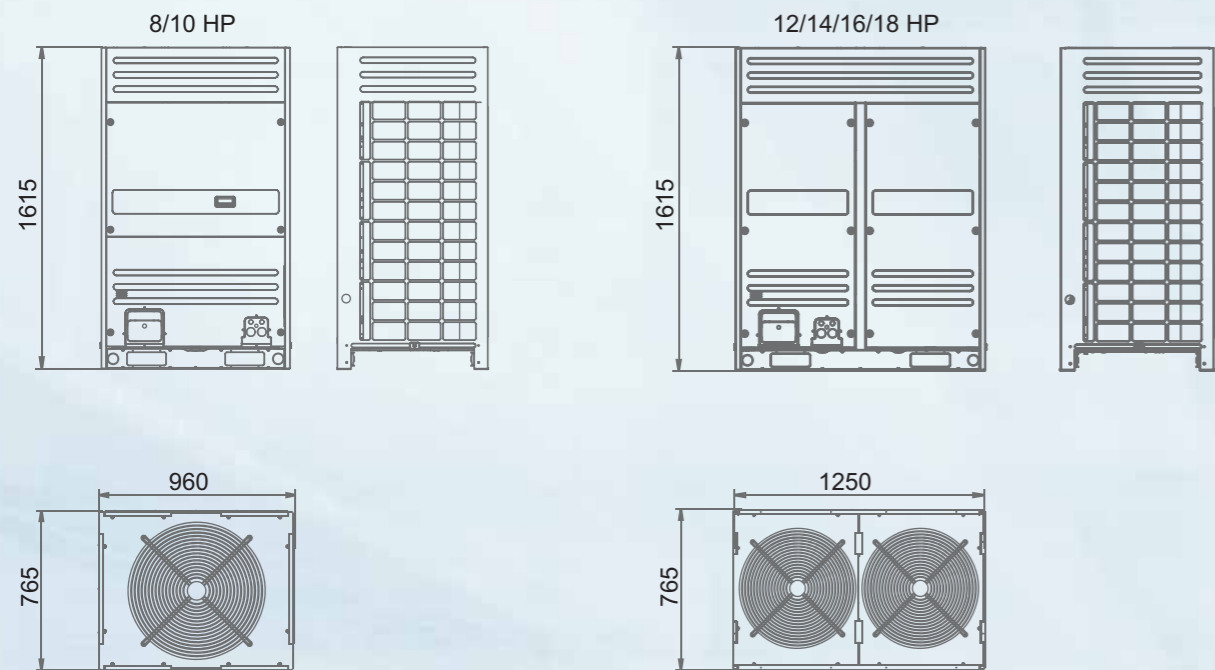

Outdoor unit - Installation dimensions (Unit: mm)

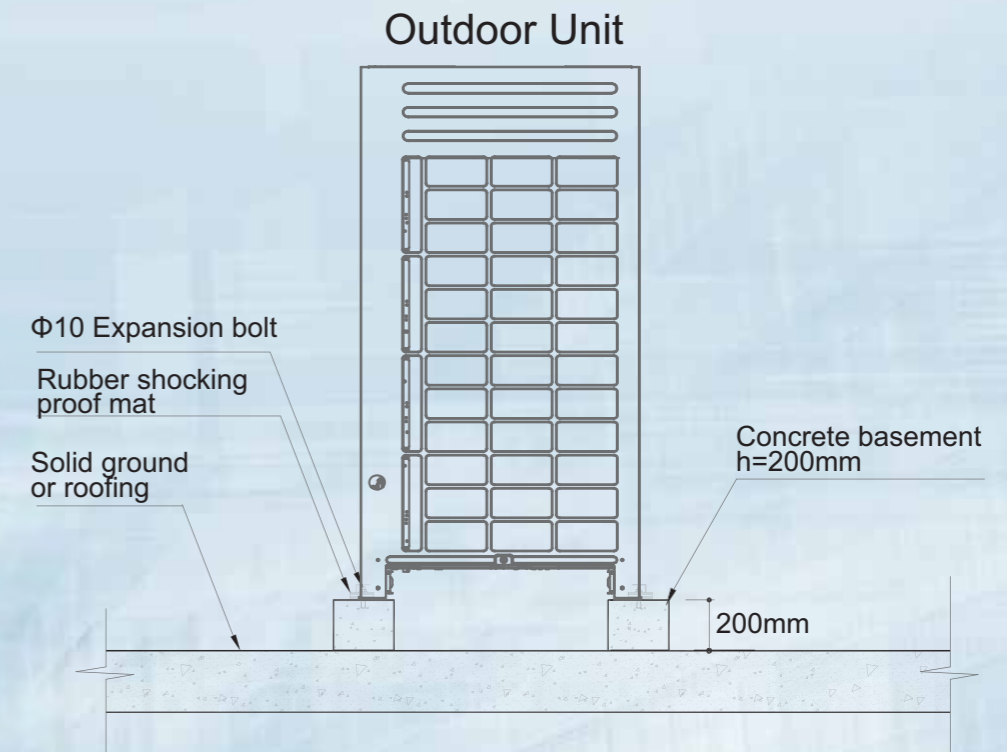

Refrigerant Piping Connections (Unit : mm)

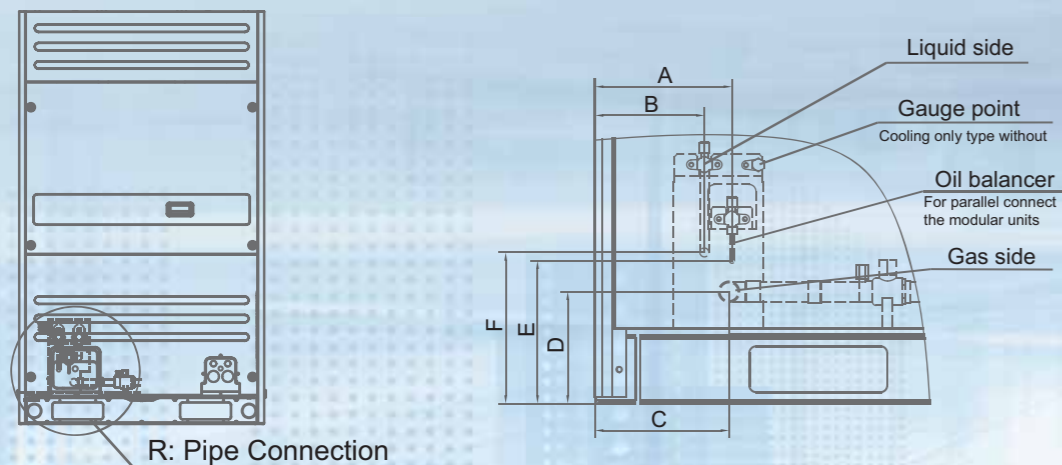

R Section View

HP SIZE	8	10	12	14	16	18
A	199	199	169	169	169	169
B	159	159	209	209	209	209
C	195	195	169	169	169	169
D	168	168	168	168	168	168
E	208	208	208	208	208	208
F	220	220	220	220	220	220
Liquid pipe	ODΦ12.7	ODΦ12.7	ODΦ15.9	ODΦ15.9	ODΦ15.9	ODΦ19.1
Gas pipe	ODΦ25.4	ODΦ25.4	ODΦ31.8	ODΦ31.8	ODΦ31.8	ODΦ31.8

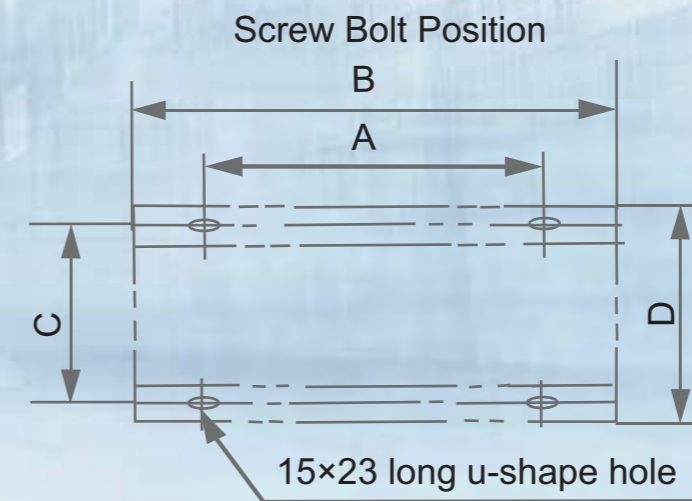

HP SIZE	8/10	12/14/16/18
A	830	1120
B	960	1250
C	736	736
D	765	765

Notes:

- (1) Ensure that the outdoor unit is installed in a dry, well-ventilated place.
- (2) Ensure that the noise and exhaust ventilation of the outdoor unit do not affect the neighbors of the property owner or the surrounding ventilation.
- (3) Ensure that the outdoor unit is installed in a well-ventilated place that is possibly closest to the indoor unit.
- (4) Ensure that the outdoor unit is installed in a cool place without direct sunshine exposure or direct radiation of high-temp heat source.
- (5) Do not install the outdoor unit in a dirty or severely polluted place, so as to avoid blockage of the heat exchanger in the outdoor unit.
- (6) Do not install the outdoor unit in a place with oil pollution or full of harmful gases such as sulfurous gas.
- (7) Do not install the outdoor unit in a place surrounded by salty air. (Except for the models with corrosion-resistant function.)

XPOWER VRF V4+ Individual

DESIGN LAYOUT

- Top discharge
- 2 Pipe system
- Individual design
- Space saving



- Integrated design of individual outdoor unit saves the installation distance between two modular outdoor units to reduce the area.
- Simple installation with less at site works and less installation cost
Simple and easy arrangement of piping inside the individual outdoor unit to facilitate installation, service and maintenance. see fig.
 - Total capacity % range of indoor units is 50% ~ 130%
 - Ambient temperature range – Cooling is -5°C ~ 48°C
 - Ambient temperature range – Heating is -20°C ~ 27°C

New designed grille reduces the wind resistance and increase the flow volume.



New designed fan shape decreases the noise.

Fig. Individual outdoor unit 30HP (Example)

Table : Individual Outdoor units lineup – individual type

One single individual outdoor unit	Capacity HP	Maximum quantity of indoor units
	20	33
	22	36
	24	39
	26	43
	28	46
	30	50
	32	53

FLEXIBLE LONG PIPING LENGTH

VRF DC Inverter system provides an actual total piping length of 1000 m, a maximum of 110 m between outdoor and indoor units.

The height difference between indoor units can be up to 30 m

These generous allowances facilitate an extensive array of system design making VRF DC Inverter perfect for large projects.

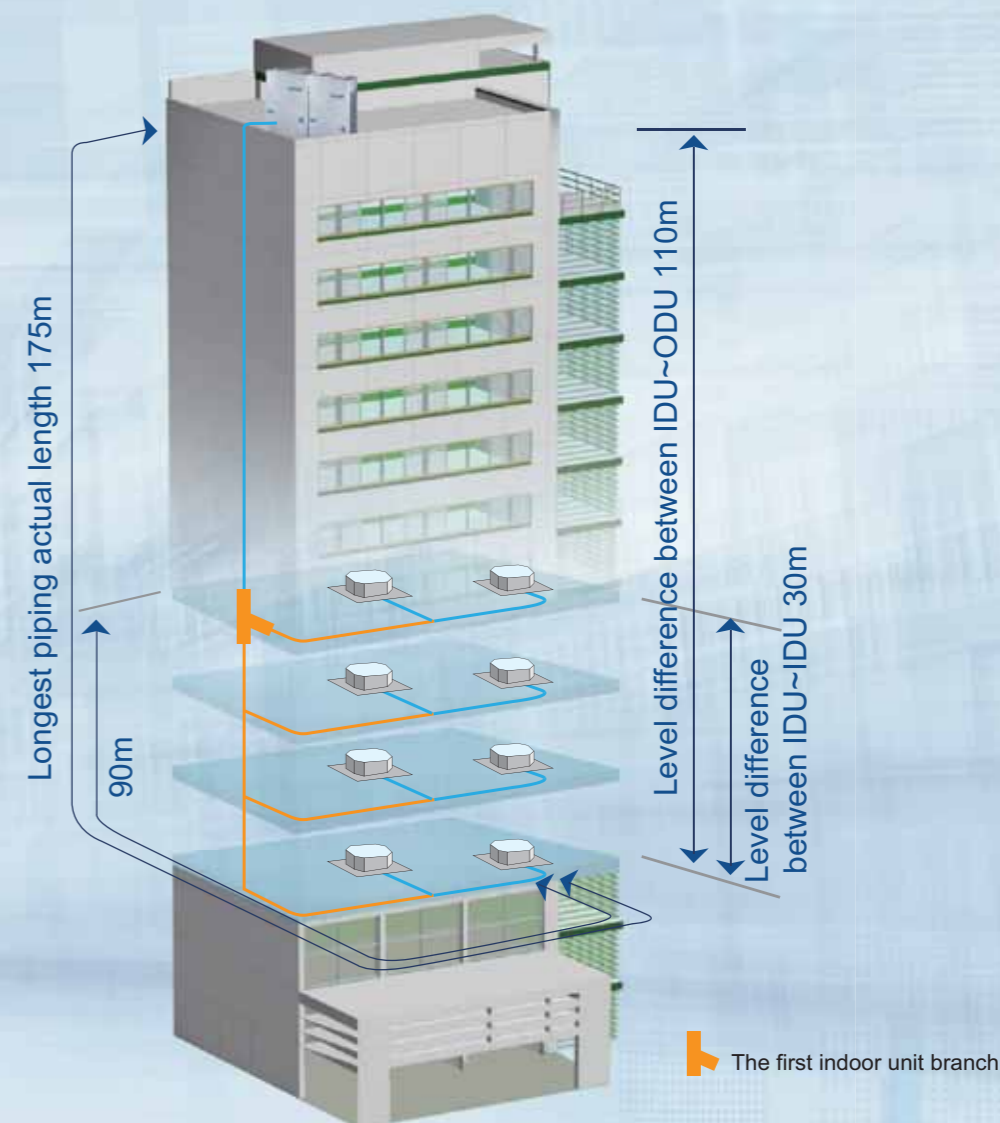

			Permitted value
Piping length	Total piping length*1 (Actual)		1000m
	Longest piping (L)	Actual length	175m
		Equivalent length	200m
Piping (The farthest IDU from the first Indoor unit branch) equivalent length			40m/90m*2
Level difference	Level difference between IDU~ODU	Outdoor unit up	70m
		Outdoor unit down	110m
	Level difference between IDU~IDU		30m

*1 Total pipe length is equal to two times orange pipe length plus blue pipe length.
*2 When the farthest pipe length is more than 40m. It needs to meet the specific conditions according to the installation manual.

INDIVIDUAL OUTDOOR UNITS – V4+I



20 HP - 32 HP

Technical specifications

Outdoor Unit Model		38VR020H119013	38VR022H119013	38VR024H119013	38VR026H119013	38VR028H119013	38VR030H119013	38VR032H119013	
Power supply	V-Ph-Hz	380~415V-3Ph-50Hz							
Cooling (*1)	Capacity	kW	56	61.5	67	73.0	78.5	85.0	90.0
		Btu/h	191072	209838	228604	249076	267842	290020	307080
	Input power	kW	17.0	18.8	20.8	22.3	24.2	26.5	28.1
	EER	W/W	3.29	3.27	3.22	3.27	3.24	3.20	3.20
Heating (*1)	Capacity	kW	63	69	75	81.5	87.5	95	100
		Btu/h	215017	235494	255973	278157	298635	324232	341297
	Input power	kW	16.0	17.9	19.8	20.6	22.4	25.0	26.5
	COP	W/W	3.94	3.85	3.79	3.96	3.91	3.80	3.77
Compressor	Quantity	1 + 2	1 + 2	1 + 2	1 + 3	1 + 3	1 + 4	1 + 4	
	Type	DC Inverter + Fixed Frequency (High Efficiency Scroll)							
Maximum quantity of connected indoor units		33	36	39	43	46	50	53	
Outdoor air flow	m ³ /h	20000	23000	23000	33100				
Outdoor sound level (*2)	dB(A)	62	63	63	64	64	65	65	
Outdoor unit	Dimension (W*H*D)	mm	1390*1615*765	1585*1615*765		2540 x 1615 x 765			
	Packing (W*H*D)	mm	1455*1790*830	1650*1810*840		2600 x 1800 x 825			
	Net/ Gross weight	Kg	360 / 375	385 / 400	390 / 405	555/590	555/590	600/635	600/635
Refrigerant (*3) Piping Lines	Liquid	mm	Φ19.1			Φ22.2			
	Gas	mm	Φ31.8			Φ38.1			

1. Nominal conditions

	Indoor	Outdoor	Pipe length	Level difference
Cooling	27°C DB (80.6°F), 19°C WB (66°F)	35°C DB (95°F)	7.5m	0m
Heating	20°C DB (68°F), 15°C WB (44.6°F)	7°C DB (42.8°F)	7.5m	0m

2. Sound level: Anechoic chamber conversion value, measured at a position 1m in front of the unit and 1.5m above the floor.

3. Refrigerant pipe dim. listed here only for when the total equivalent length < 90m. For the data when total equivalent length 90 m please refer to technical manual.

XPOWER VRF V4+ S Full DC Inverter

DESIGN LAYOUT

- Top discharge
- 2 Pipe system
- Modular design
- 6 basic modules, which can freely be combined in the installation site for wide range and large capacity for big sizes buildings.
- 2HP increment of capacity range, which meets customers needs accurately.
- Outdoor unit with all DC Inverter Compressor (s) + all DC fan motor (s)

Outdoor Unit (Module)	Compressor Quantity		Outdoor Fan Motor Quantity
	DC Inverter Compressor (1)	DC Inverter Compressor (2)	DC Fan Motor
8 HP	1		1
10 HP	1		1
12 HP	1	1	2
14 HP	1	1	2
16 HP	1	1	2
18 HP	1	1	2

- Maximum capacity is 72 HP
- Maximum quantity of outdoor units is 4
- Maximum quantity of indoor units is 64
- Total capacity % range of indoor units is 50% ~ 130%



FEATURES

FLEXIBLE WIDE APPLICATION RANGE

Wide operation range

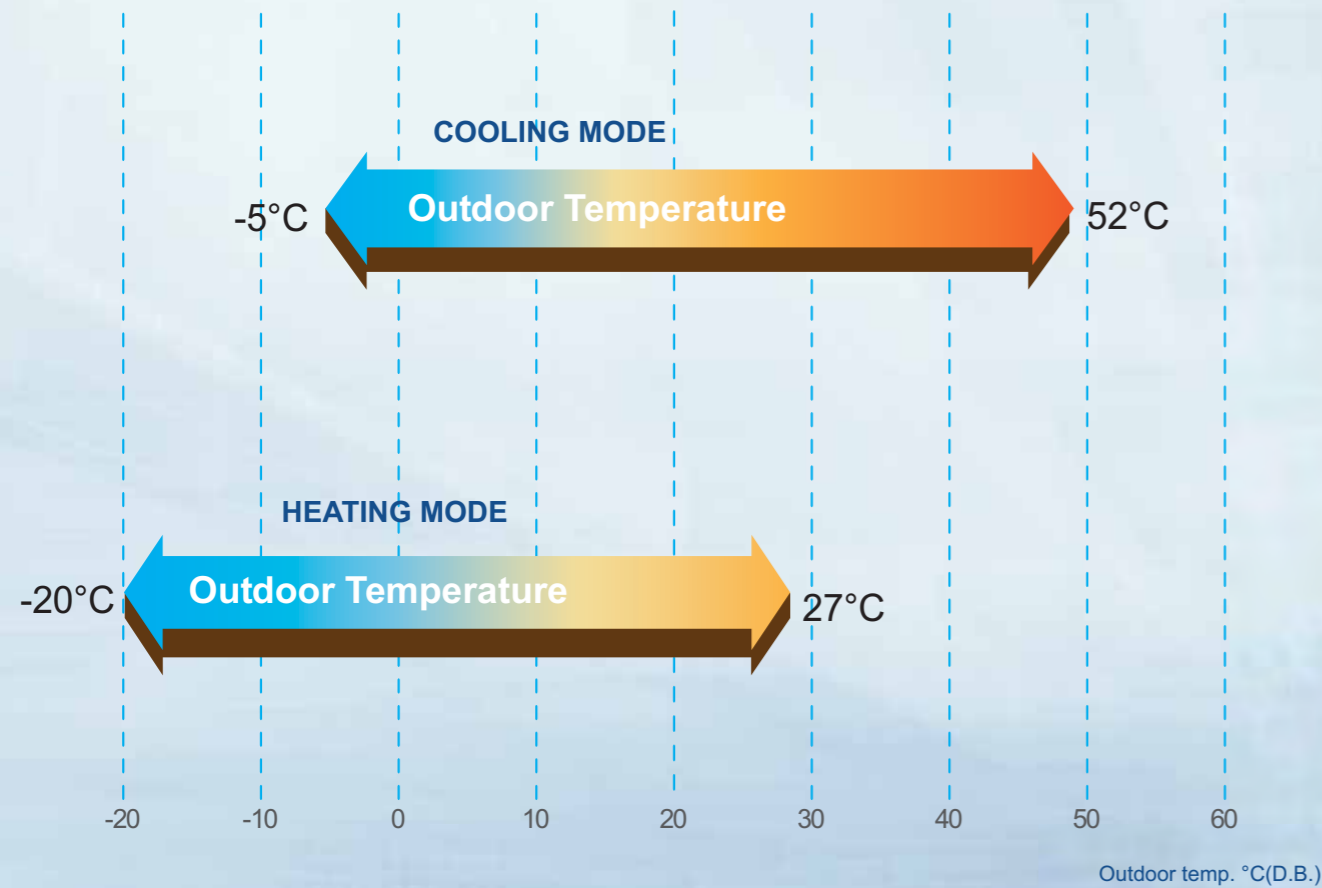

VRF Full DC Inverter system operates stably at extreme outdoor temperature range from -5°C to 52°C in cooling and from -20°C to 27°C in heating.

Extra high static pressure – max. 40Pa and air volume increased by 10%

- High-static pressure propeller and optimized fan guard can adapt to various installation environments.
- Carrier now offers up to 40 Pa* external static pressure units for customized applications.
- Standard 0-20Pa function is equipped by default.

* You need to consult Carrier sales team if you require over 40Pa external static pressure .



Flexible long piping length

VRF DC Inverter system provides an actual total piping length of 1000 m, a maximum of 110 m between outdoor and indoor units.

The height difference between outdoor units can be up to 8 m

These generous allowances facilitate an extensive array of system design making VRF DC Inverter perfect for large projects.

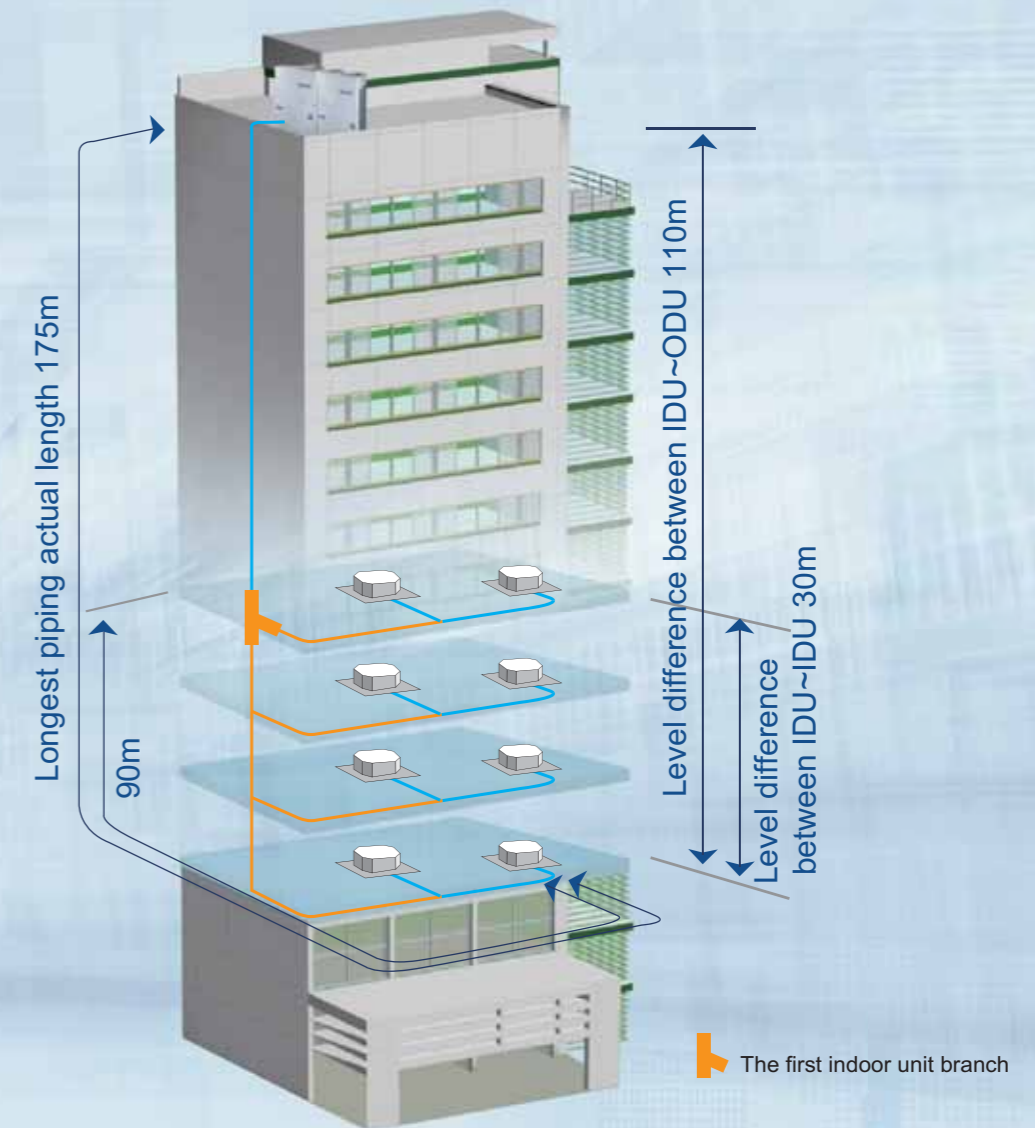

			Permitted value
Piping length	Total piping length*1 (Actual)		1000m
	Longest piping (L)	Actual length	175m
		Equivalent length	200m
Piping (The farthest IDU from the first Indoor unit branch) equivalent length			40m/90m ^{*2}
Level difference	Level difference between IDU-ODU	Outdoor unit up	70m
		Outdoor unit down	110m
	Level difference between IDU-IDU		30m

*1 Total pipe length is equal to two times orange pipe length plus blue pipe length.

*2 When the farthest pipe length is more than 40m.

It needs to meet the specific conditions according to the installation manual.

High efficiency heat exchanger

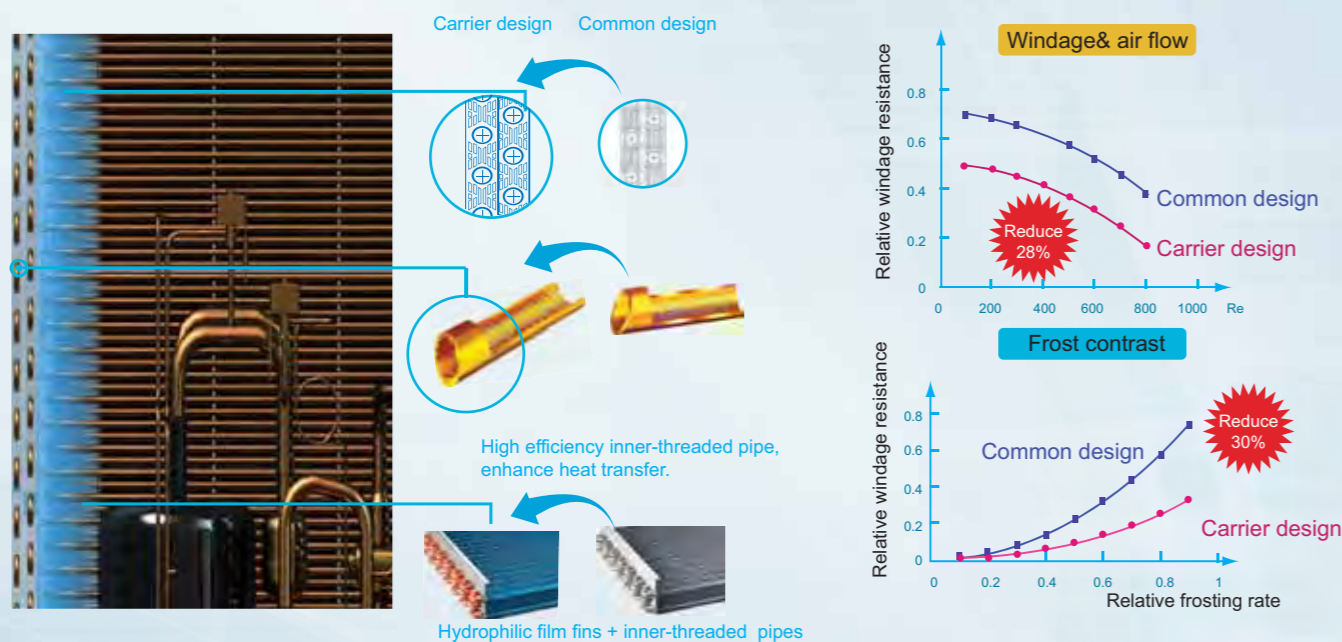

- The new designed window fins enlarge the heat-transfer area, decrease the air resistance, save more power and enhance heat transfer performance in cooling and heating.
- Hydrophilic aluminum fins and inner-groove copper tubes optimize heat transfer efficiency.

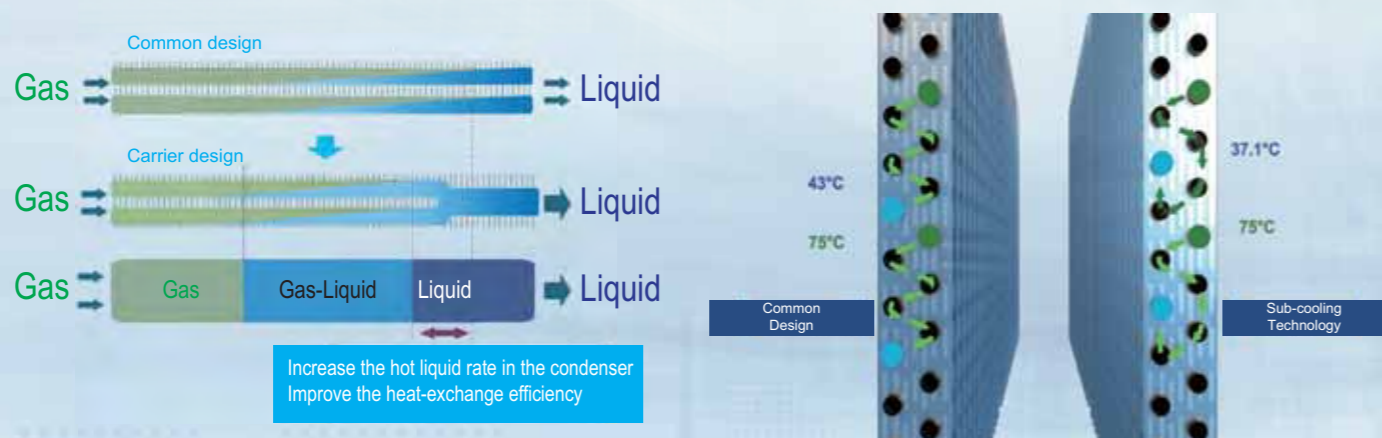

- Innovative designed high efficiency heat exchanger, which can reach up to 12°C subcooling degree, reduces the system resistance and improves reliability.
- When the outdoor temperature is 35°C, the refrigerant can be cooled down to 37.1°C, thus achieving high heat-transfer efficiency with only 2.1°C temperature difference.

High pressure sensor

- Controls the discharge pressure of the compressor and to control the fan speed.



Always test the system pressure



Every 20 seconds, compare the system pressure and the best pressure to adjust DC fan motor speed timely.

HIGH EFFICIENCY

High EER / High COP values

VRF FULL DC Inverter Series with all high efficiency DC Inverter scroll compressors all, DC motors and high efficiency heat exchanger, achieve the world's Top Class energy efficiency. Cooling EER up to 4.29 and Heating COP up to 4.39 in the 8HP category.

EER

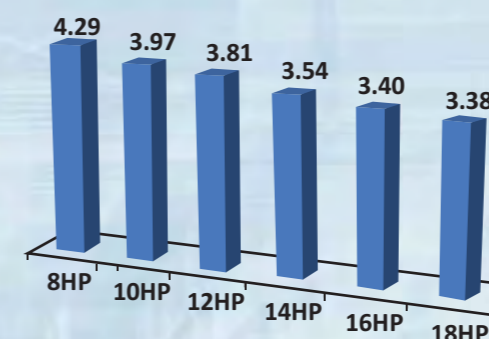

COP

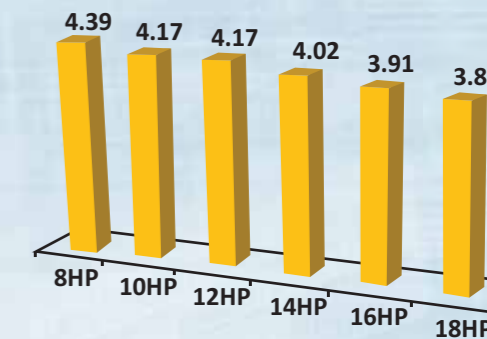

Multi solenoid valves control technology

Multi solenoid valves control technology and double EEV control technology in one VRF system.

All the solenoid valves equipped in the unit ensure temperature-control precisely, system running steadily and economic to provide a comfortable environment.

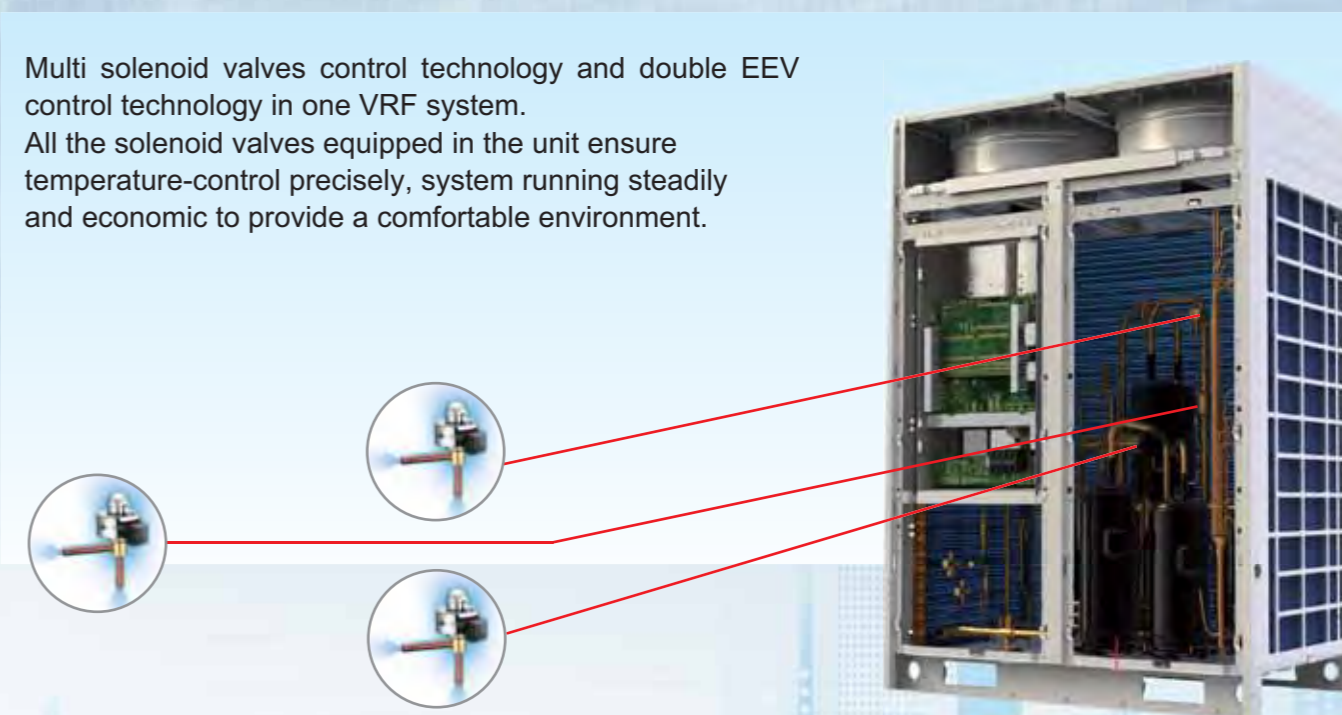

MODULAR OUTDOOR UNITS – V4+S



8 HP - 10 HP



12 HP

■ Technical specifications

Outdoor Unit Model			38VF008H119010	38VF010H119010	38VF012H119010
Power supply		V-Ph-Hz	380~415V-3Ph-50Hz	380~415V-3Ph-50Hz	380~415V-3Ph-50Hz
Cooling (*1)	Capacity	kW	25.2	28	33.5
		Btu/h	85,982	95,536	114,302
	Input	kW	5.8	7.1	8.8
	EER	W/W	4.29	3.97	3.81
Heating (*1)	Capacity	kW	27	31.5	37.5
		Btu/h	92,124	107,478	127,950
	Input	kW	6.1	7.6	9.0
	COP	W/W	4.39	4.17	4.17
Compressor	Quantity		1	1	1 + 1
	Type		DC Inverter	DC Inverter	DC Inverter
Outdoor Fan Motor	Quantity		1	1	2
	Type		DC Motor	DC Motor	DC Motor
Maximum quantity of connected indoor units			13	16	20
Outdoor air flow		m ³ /h	11242	11242	15620
Outdoor sound level (*2)		dB(A)	57	57	59
Outdoor unit	Dimension(W*H*D)	mm	960*1615*765	960*1615*765	1250*1615*765
	Packing (W*H*D)	mm	1025*1790*830	1025*1790*830	1305*1790*820
	Net/Gross weight	kg	212 / 227	212 / 227	288 / 308
Refrigerant Piping Lines (*3)		Gas	Ø 25.4	Ø 25.4	Ø 31.8
		Liquid	Ø 12.7	Ø 12.7	Ø 15.9

1.Nominal conditions

	Indoor	Outdoor	Pipe length	Level difference
Cooling	27°C DB (80.6°F), 19°C WB (66°F)	35°C DB (95°F)	7.5m	0m
Heating	20°C DB (68°F), 15°C WB (44.6°F)	7°C DB (42.8°F)	7.5m	0m

2.Sound level: Anechoic chamber conversion value, measured at a position 1m in front of the unit and 1.5m above the floor.

3.Refrigerant pipe dim.listed here only for when the total equivalent length < 90m. For the data when total equivalent length 90 m please refer to technical manual.



14 HP - 16 HP



18 HP

■ Technical specifications

Outdoor Unit Model			38VF014H119010	38VF016H119010	38VF018H119010
Power supply		V-Ph-Hz	380~415V-3Ph-50Hz	380~415V-3Ph-50Hz	380~415V-3Ph-50Hz
Cooling (*1)	Capacity	kW	40	45	50
		Btu/h	1,36,480	1,53,540	1,70,600
	Input	kW	11.3	13.2	14.8
	EER	W/W	3.54	3.40	3.38
Heating (*1)	Capacity	kW	45	50	56
		Btu/h	153,540	170,600	191,072
	Input	kW	11.2	12.8	14.4
COP	W/W	4.02	3.91	3.89	
Compressor	Quantity		1 + 1	1 + 1	1 + 1
	Type		DC Inverter	DC Inverter	DC Inverter
Outdoor Fan Motor	Quantity		2	2	2
	Type		DC Motor	DC Motor	DC Motor
Maximum quantity of connected indoor units			23	26	29
Outdoor air flow		m ³ /h	15620	15620	15770
Outdoor sound level (*2)		dB(A)	61	62	62
Outdoor unit	Dimension(W*H*D)	mm	1250*1615*765	1250*1615*765	1250*1615*765
	Packing (W*H*D)	mm	1305*1790*820	1305*1790*820	1305*1790*820
	Net/Gross weight	kg	288/308	288/308	310/330
Refrigerant Piping Lines (*3)		Gas	Ø 31.8	Ø 31.8	Ø 31.8
		Liquid	Ø 15.9	Ø 15.9	Ø 19.1

1.Nominal conditions

	Indoor	Outdoor	Pipe length	Level difference
Cooling	27°C DB (80.6°F), 19°C WB (66°F)	35°C DB (95°F)	7.5m	0m
Heating	20°C DB (68°F), 15°C WB (44.6°F)	7°C DB (42.8°F)	7.5m	0m

2.Sound level: Anechoic chamber conversion value, measured at a position 1m in front of the unit and 1.5m above the floor.

3.Refrigerant pipe dim.listed here only for when the total equivalent length < 90m. For the data when total equivalent length 90 m please refer to technical manual.

DIMENSIONAL DETAILS

Outdoor Unit dimensions (Unit : mm)

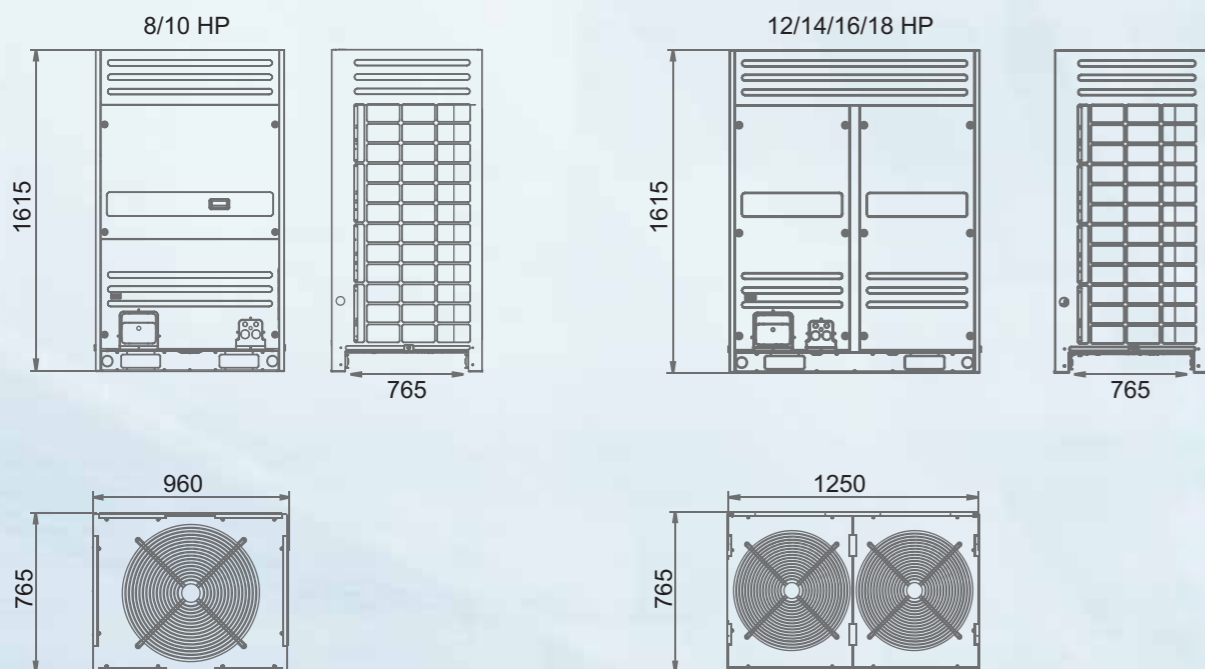

Refrigerant Piping Connections (Unit : mm)

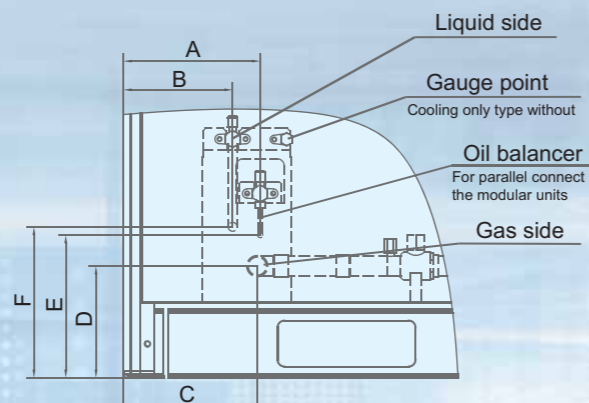
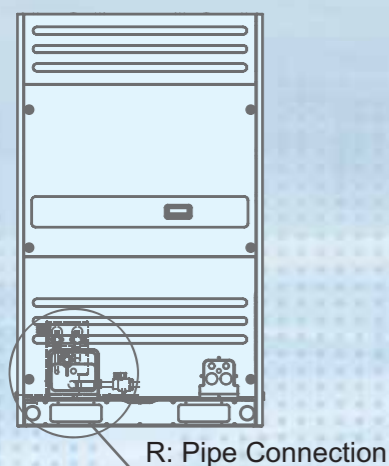

R Section View

HP SIZE	8	10	12	14	16	18
A	199	199	169	169	169	169
B	159	159	209	209	209	209
C	195	195	169	169	169	169
D	168	168	168	168	168	168
E	208	208	208	208	208	208
F	220	220	220	220	220	220
Liquid pipe	ODΦ12.7	ODΦ12.7	ODΦ15.9	ODΦ15.9	ODΦ15.9	ODΦ19.1
Gas pipe	ODΦ25.4	ODΦ25.4	ODΦ31.8	ODΦ31.8	ODΦ31.8	ODΦ31.8

XPOWER Mini VRF

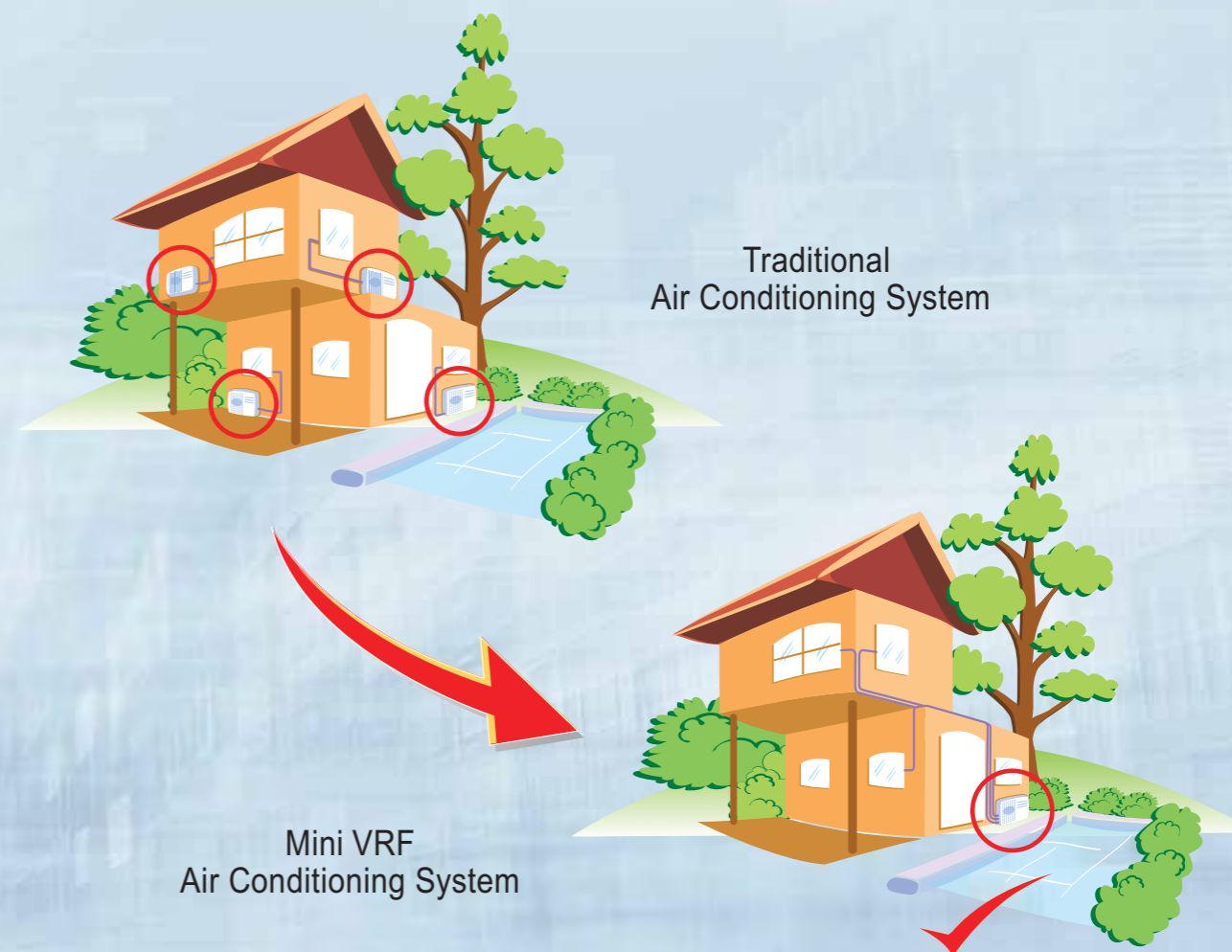

Carrier MINI VRF Inverter system is a highly efficient solution for small commercial buildings that requiring heating and cooling system up to 8 zones in one outdoor unit. Carrier offers more than 100 models in about 15 types indoor units can be combined with MINI VRF Inverter outdoor unit and Max indoor unit is 15, which provides individual comfort space, easy installation and control. This is a flexible system that bridges the capacity gap between VRF and Multi systems – ideal for commercial and private applications.

Mini VRF DC Inverter System Line - up



Indoor Unit (kW)	1.8	2.2	2.8	3.6	4.5	5.6	7.1	8.0	9.0	10.0	10.5	11.2	14.0	16.0	20.0	25.0	28.0
One-way Cassette		✓	✓	✓	✓	✓	✓										
Two-way Cassette		✓	✓	✓	✓	✓	✓										
Four-way Cassette Compact		✓	✓	✓	✓												
Four-way Cassette			✓	✓	✓	✓	✓	✓	✓	✓		✓	✓				
Low Static Pressure Ducted	✓	✓	✓	✓	✓	✓	✓										
Medium Static Pressure Ducted		✓	✓	✓	✓	✓	✓	✓	✓			✓	✓				
High Static Pressure Ducted							✓	✓	✓			✓	✓	✓	✓	✓	✓
Floor / Ceiling					✓	✓	✓	✓	✓		✓	✓					
High Wall		✓	✓	✓	✓	✓	✓	✓									
Exposed Floor-standing		✓	✓	✓	✓	✓	✓	✓									
Concealed Floor-standing		✓	✓	✓	✓	✓	✓	✓									
Console		✓	✓	✓	✓												

Residential & Light Commercial Applications



Luxury Apartments



Villas



Restaurants



Offices

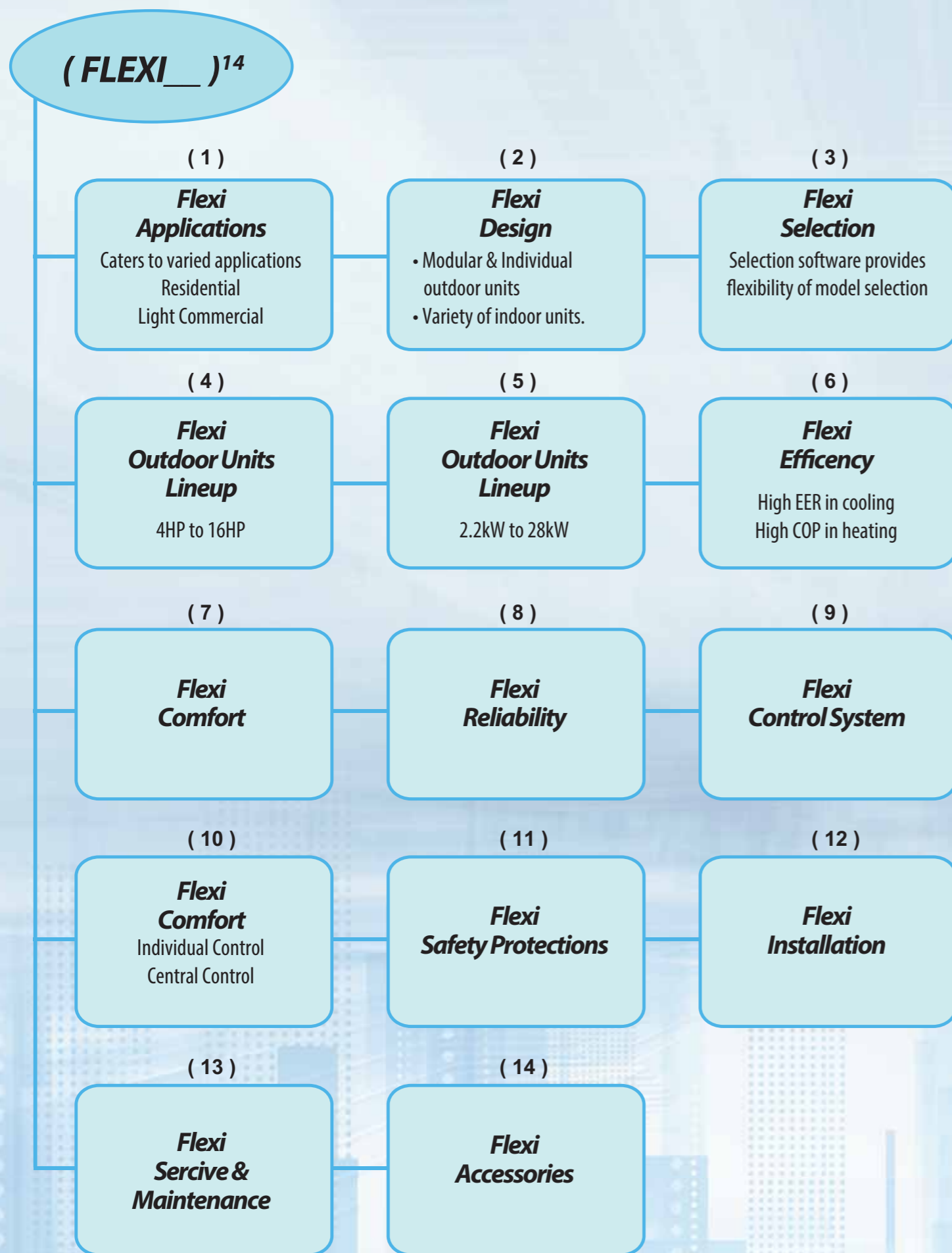

SIDE DISCHARGE OUTDOOR UNITS – Mini VRF



Technical Specifications

Model			38VR004H112010	38VR005H112010	38VR006H112010
Power Supply		V-Ph-Hz	220 ~ 240 - 1 - 50Hz	220 ~ 240 - 1 - 50Hz	220 ~ 240 - 1 - 50Hz
Cooling(*1)	Capacity	kW	12	14	15.5
	Input	kW	3.95	4.85	5.65
	EER	W/W	3.04	2.89	2.74
Heating (*1)	Capacity	kW	13.2	15.4	17
	Input	kW	3.55	4.35	5.5
	COP		3.72	3.54	3.09
Compressor	Quantity		1	1	1
	Type		DC Inverter	DC Inverter	DC Inverter
Maximum quality of connected Inoor Unit			6	6	7
Outdoor air flow		m ³ /h	6000	6000	6000
Outdoor Sound Level (sound pressure level)(*2)		dB(A)	58	57	57
Outdoor Unit	Dimansion (W x H x D)	mm	900x1327x320	900x1327x320	900x1327x320
	Packing (W x H x D)	mm	1030x1456x435	1030x1456x435	1030x1456x435
	Net/Gross weight	kg	95/106	95/106	100/111
Design pressure		MPa	4.4/2.6	4.4/2.6	4.4/2.6
Refrigerant piping(*3)	Liquid/Gas	mm	Φ9.52 / Φ15.9	Φ9.52 / Φ15.9	Φ9.52 / Φ15.9

1.Nominal conditions

	Indoor	Outdoor	Pipe length	Level difference
Cooling	27°C DB (80.6°F), 19°C WB (66°F)	35°C DB (95°F)	7.5m	0m
Heating	20°C DB (68°F), 15°C WB (44.6°F)	7°C DB (42.8°F)	7.5m	0m

2.Sound level: Anechoic chamber conversion value, measured at a position 1m in front of the unit and 1.5m above the floor.

3.Refrigerant pipe dim.listed here only for when the total equivalent length < 90m. For the data when total quivalent length 90 m please refer to technical manual.



Technical Specifications

Model			38VR004H119010	38VR005H119010	38VR006H119010
Power Supply		V-Ph-Hz	380-415-3-50	380-415-3-50	380-415-3-50
Cooling(*1)	Capacity	kW	12	14	15.5
	Input	kW	3.9	4.75	5.6
	EER		3.08	2.95	2.77
Heating(*1)	Capacity	kW	13.2	15.4	17
	Input	kW	3.75	3.38	3.15
	COP		3.52	3.38	3.15
Compressor	Quantity		1	1	4
	Type		DC Inverter	DC Inverter	DC Inverter
Maximum quality of connected Inoor Units			6	6	7
Outdoor air flow		m ³ /h	6983	6500	6000
Outdoor Sound Level (sound pressure level)(*2)		dB(A)	57	57	57
Outdoor Unit	Dimansion (W x H x D)	mm	900x1327x320	900x1327x320	900x1327x320
	Packing (W x H x D)	mm	1030x1456x435	1030x1456x435	1030x1456x435
	Net/Gross weight	kg	95/106	95/106	102/113
Design pressure		MPa	4.4/2.6		
Refrigerant piping(*3)	Liquid/Gas	mm	Φ9.53 / Φ15.9		

1.Nominal conditions

	Indoor	Outdoor	Pipe length	Level difference
Cooling	27°C DB (80.6°F), 19°C WB (66°F)	35°C DB (95°F)	7.5m	0m
Heating	20°C DB (68°F), 15°C WB (44.6°F)	7°C DB (42.8°F)	7.5m	0m

2.Sound level: Anechoic chamber conversion value, measured at a position 1m in front of the unit and 1.5m above the floor.

3.Refrigerant pipe dim.listed here only for when the total equivalent length < 90m. For the data when total equivalent length 90 m please refer to technical manual.



Technical Specifications

Model			38VR007H11901S	38VR008H11901S	38VR010H11901S	38VR014H11901S	38VR016H11901S
Power Supply		V-Ph-Hz	380-415-3-50	380-415-3-50	380-415-3-50	380-415-3-50	380-415-3-50
Cooling(*1)	Capacity	kW	17.5	22.4	26	40	45
	Input	kW	5.3	7.2	8.4	11.9	13.6
	EER		3.30	3.11	3.10	3.35	3.32
Heating(*1)	Capacity	kW	19	24.5	28.5	45	50
	Input	kW	5	6.7	7.9	11.1	12.7
	COP		3.80	3.66	3.61	4.05	3.93
Compressor	Quantity		1	1	1	1 + 1	1 + 1
	Type		DC Inverter	DC Inverter	DC Inverter	DC Inverter	DC Inverter
Maximum quality of connected Inoor Unit			9	11	12	14	15
Outdoor air flow		m ³ /h	6800	10494	10494	16575	16575
Outdoor sound level (sound pressure level)(*2)		dB(A)	59	59	60	62	62
Outdoor Unit	Dimansion (W x H x D)	mm	900 x 1327 x 320	1120 x 1558 x 400	1120 x 1558 x 400	1360 x 1650 x 540	1460 x 1650 x 540
	Packing (W x H x D)	mm	1030 x 1456 x 435	1270 x 1575 x 480	1270 x 1575 x 480	1450 x 1785 x 560	1550 x 1785 x 560
	Net/Gross weight	kg	107/118	146.5 / 162.5	147 / 163	240/260	275/290
Refrigerant piping(*3)	Liquid side/Gas side	mm	Φ9.53 / Φ19.1	Φ9.52 / Φ19.1	Φ9.52 / Φ22.2	Φ12.7 / Φ22.2	Φ12.7 / Φ25.4

1.Nominal conditions

	Indoor	Outdoor	Pipe length	Level difference
Cooling	27°C DB (80.6°F), 19°C WB (66°F)	35°C DB (95°F)	7.5m	0m
Heating	20°C DB (68°F), 15°C WB (44.6°F)	7°C DB (42.8°F)	7.5m	0m

2.Sound level: Anechoic chamber conversion value, measured at a position 1m in front of the unit and 1.5m above the floor.

3.Refrigerant pipe dim.listed here only for when the total equivalent length < 90m. For the data when total equivalent length 90 m please refer to technical manual.

Mini VRF DC Inverter Outdoor Unit Capacity	Maximum Quantity of Indoor Units
12 KW	6
14 KW	6
15.5 KW	7
17.5 KW	9
22.4 KW	11
26 KW	12
40 KW	14
45 KW	15

Using Branch Joints for refrigerant piping connections between outdoor unit and indoor units



Using Branch box for refrigerant piping connections between outdoor unit and indoor units



Wide Stable Operation Range

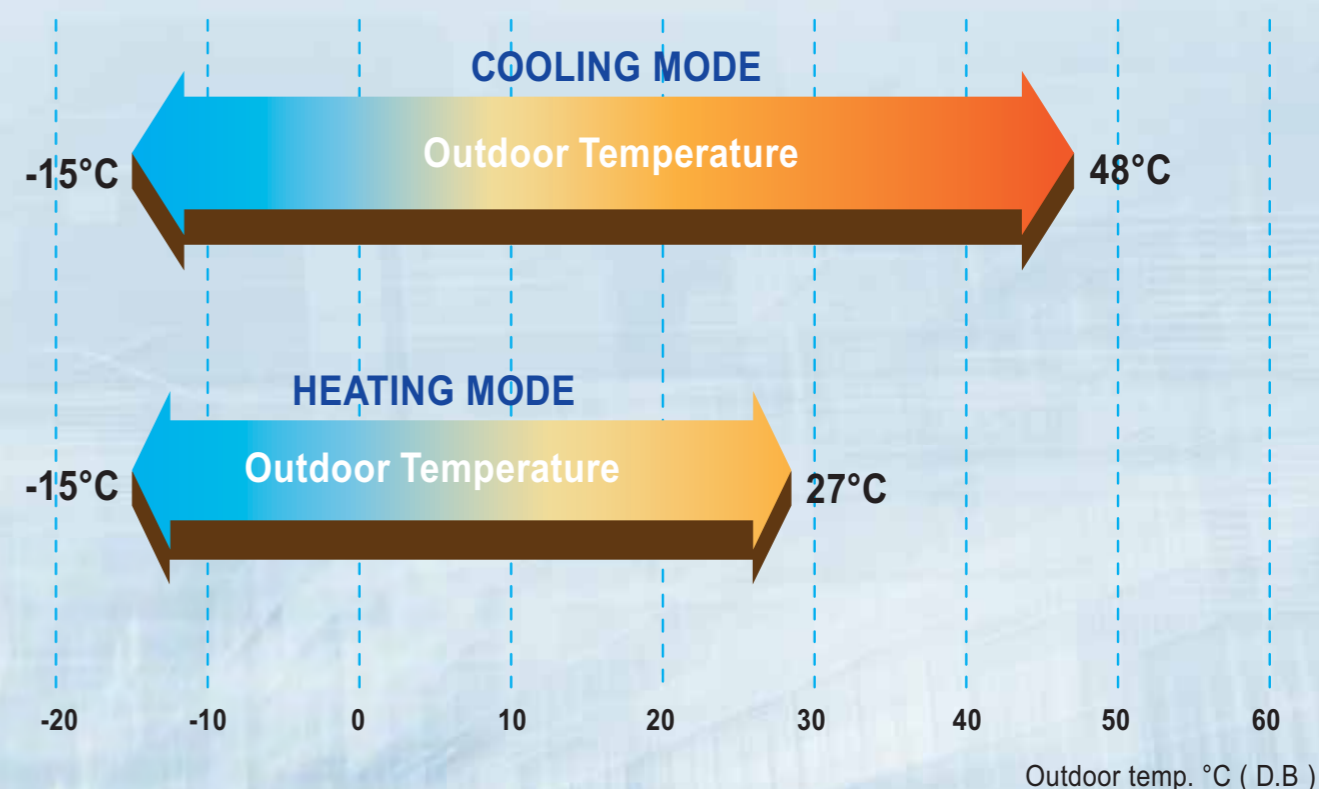

Space Saving Design

MINI VRF units are slimmer and more compact, resulting in significant savings in installation space. In some large residential spaces or some light commercial space, such as villa, restaurant, usually it need more than one indoor unit, so outside the building are also full of outdoor units. Now Carrier can provide an effective solution-Carrier MINI VRF DC Inverter system. Since now the beauty of the building will be back.

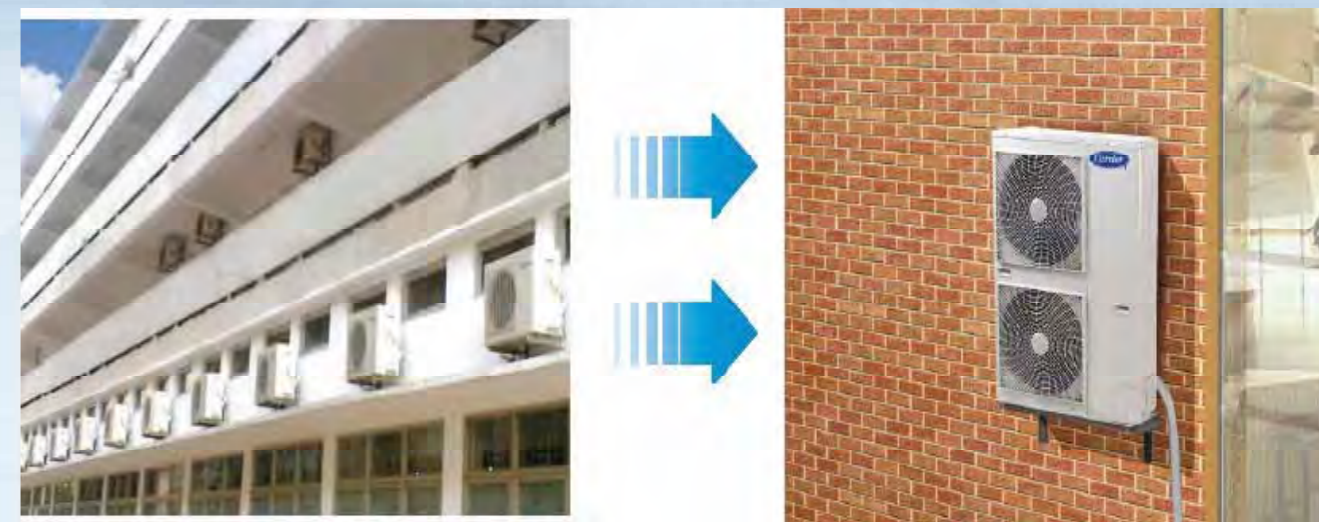

Traditional Air Conditioning

MINI VRF

Long Piping Length

- Mini VRF provides 100 m Actual Total Piping Length.
- The height difference between outdoor unit and indoor units can be up to a maximum of (ODU Up 20m or ODU Down 30m).
- The height difference between indoors unit can be up to a maximum of 8m.
- These generous allowances facilitate an extensive variety of system designs.

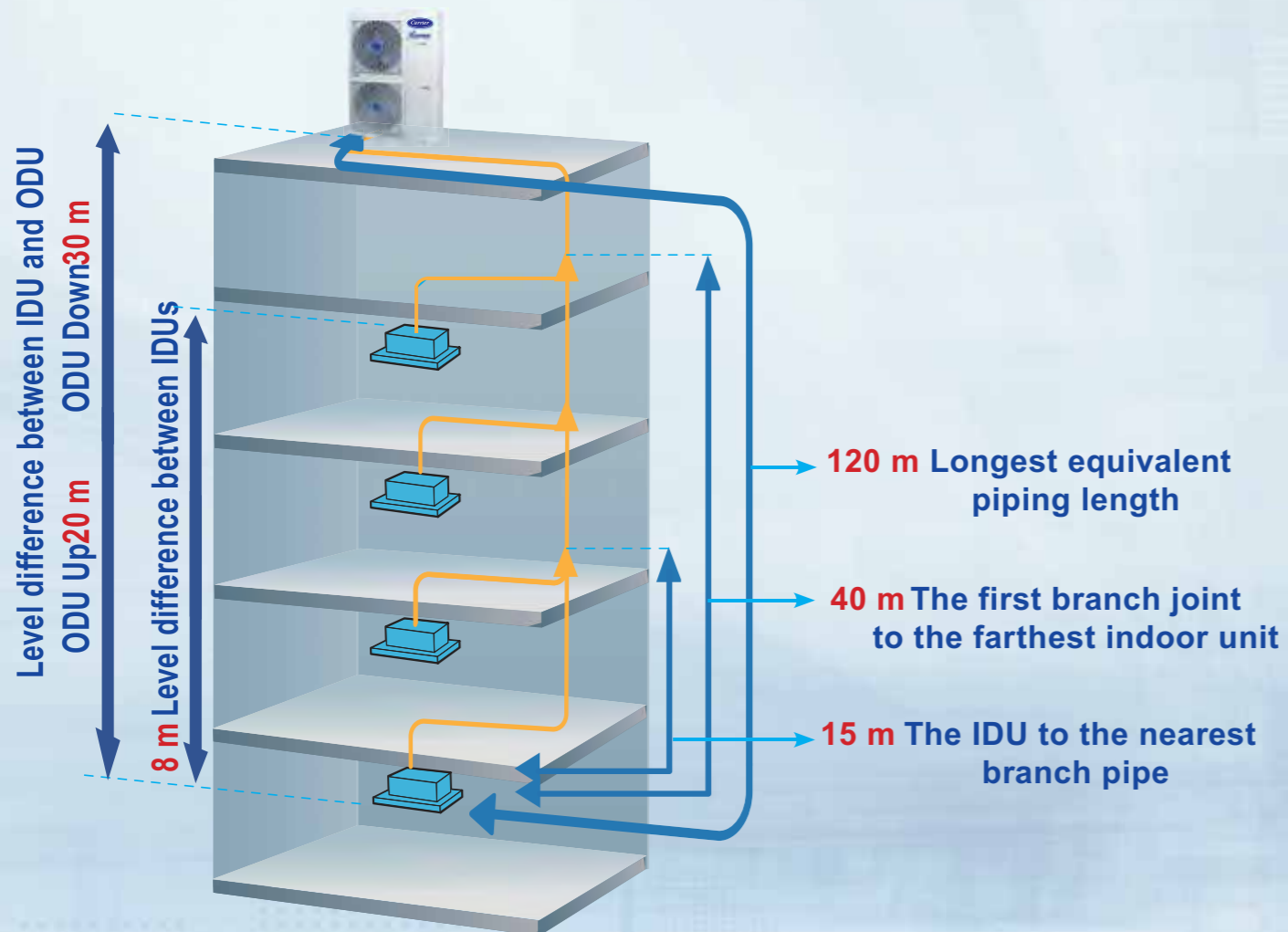

Permitted value (m)		12 - 14 - 15.5 kW	22.4 - 26 kW	40 - 45 kW	
Piping Length	Actual Total Piping Length(*1)	100 m	120 m	250 m	
	Longest Piping	Actual Length	60 m	60 m	100 m
		Equivalent Length	70 m	70 m	120 m
Equivalent Piping Length (The farthest IDU to the first Indoor unit branch)		20 m	20 m	40 m	
Level Difference	Level Difference Between IDU~ODU	Outdoor Unit Up	30 m	30 m	30 m
		Outdoor Unit Down	20 m	20 m	20 m
	Level Difference Between IDU~IDU		8 m	8 m	8 m

*1 Total pipe length is equal to all liquid pipe or all the gas pipe length.

High Efficiency MINI VRF DC Inverter Outdoor Unit

High Efficiency Fan Housing & Outlet Grille



Newly Designed Fan Guard

New designed fan guard

Air deflector

New designed fan

High Efficiency Outdoor Fan (s)

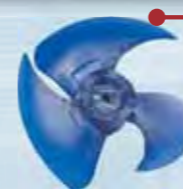

High Efficiency DC Fan Motor



High Efficiency Outdoor Coil

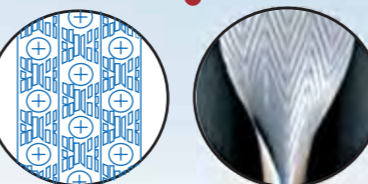

High Efficiency DC Inverter Twin Rotary Compressor



High Efficiency DC Inverter Rotary Compressor Technology

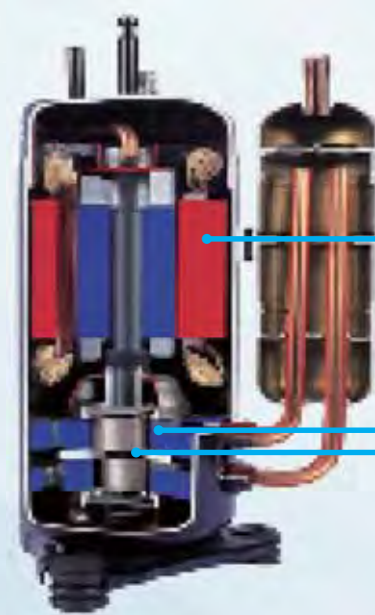

Compressor
(Twin Rotary)
structure

Highly Efficient DC Motor:

- Creative motor core design.
- High density neodymium magnet.
- Concentrated type stator.
- Wider operating frequency range.

Better balance and Extremely Low Vibration:

- Twin eccentric cams.
- 2 balance weights.

Highly Stable Moving Parts:

- Optimal material matching rollers and vanes
- Optimize compressor drive technology.
- Highly robust bearings.
- Compact structure.

Compact Design for Effective Use of Space

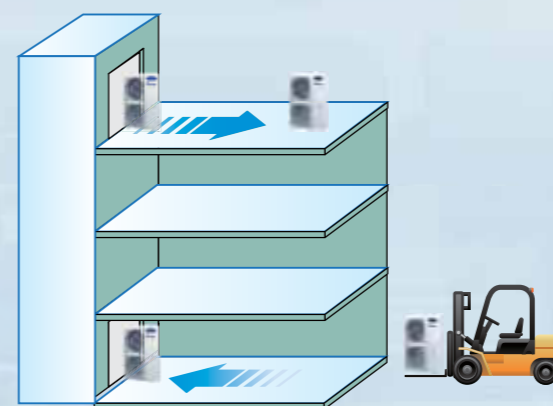

Compact size and light weight design minimizes the installation footprint, reduces the installation floor load, and is easier for transportation. For some projects the units can even be transported through the elevator or forklift, reduce access problem at the jobsite and reduce time and labor.

More convenience in installation

A four-direction space is available for connecting pipes and wiring in various installation sites.

For installation in different types of rooms in small offices and shops, the Mini VRF system offers a wide range of indoor and outdoor units. These are almost as easy to install as residential air conditioning systems, making them the ideal choice.

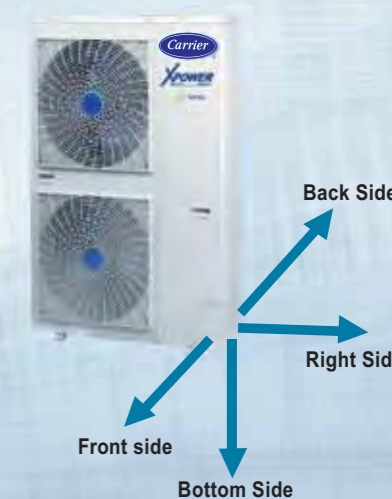
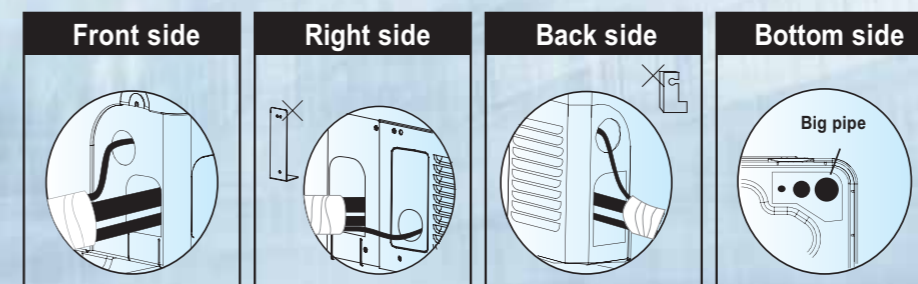

Simple Signal Line Connection

Installation is easier as communication wiring can be shared by indoor & outdoor units. It's easy for the user to retrofit the existing system with a centralized control by simply connecting to the outdoor units.

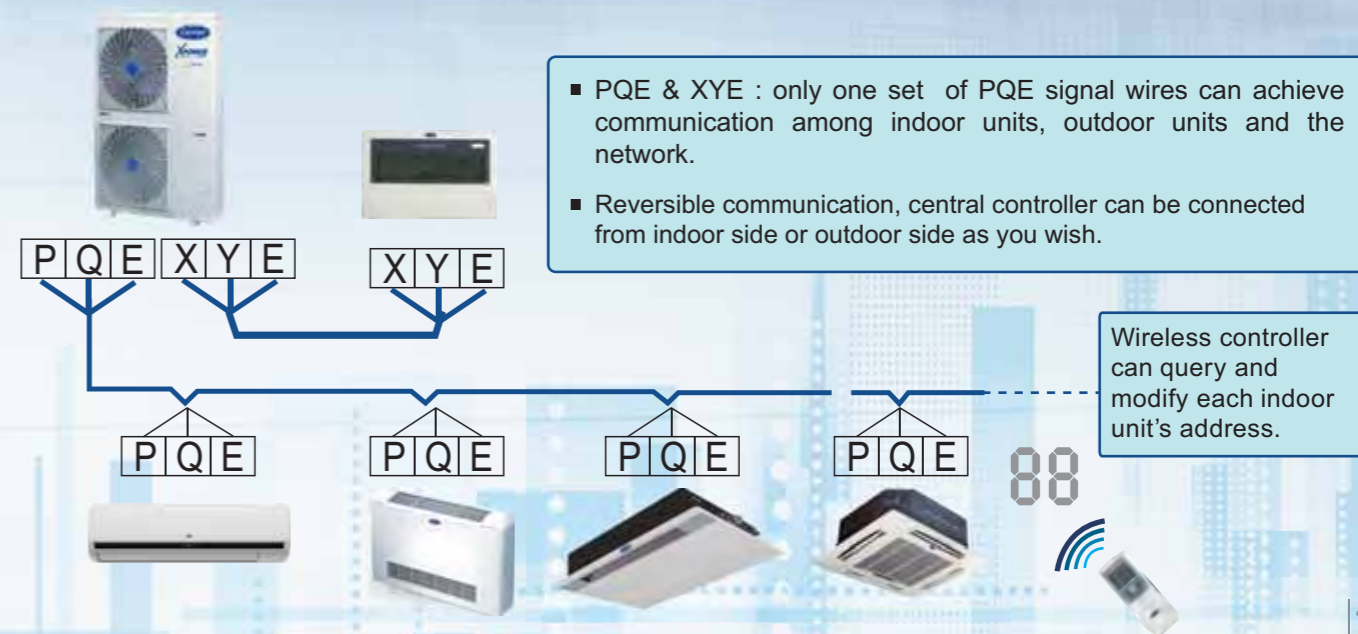

Powerful magnets provide high torque and efficiency and achieve 70% reduction in volume.

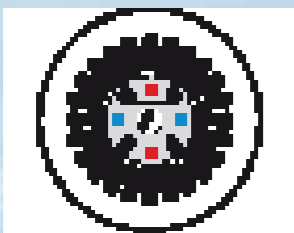

Centralizing winding

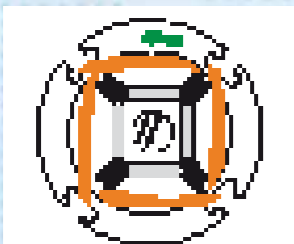

Distributing winding

- New DC motor-centralized winding
- Common DC motor-distributing winding

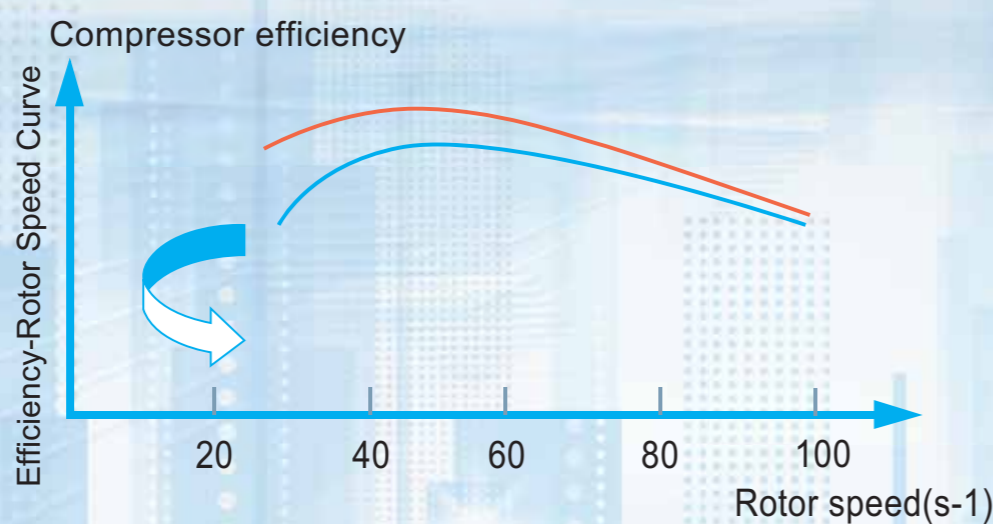

Dimensions of MINI VRF DC Inverter - Outdoor Units

Dimensions (mm)

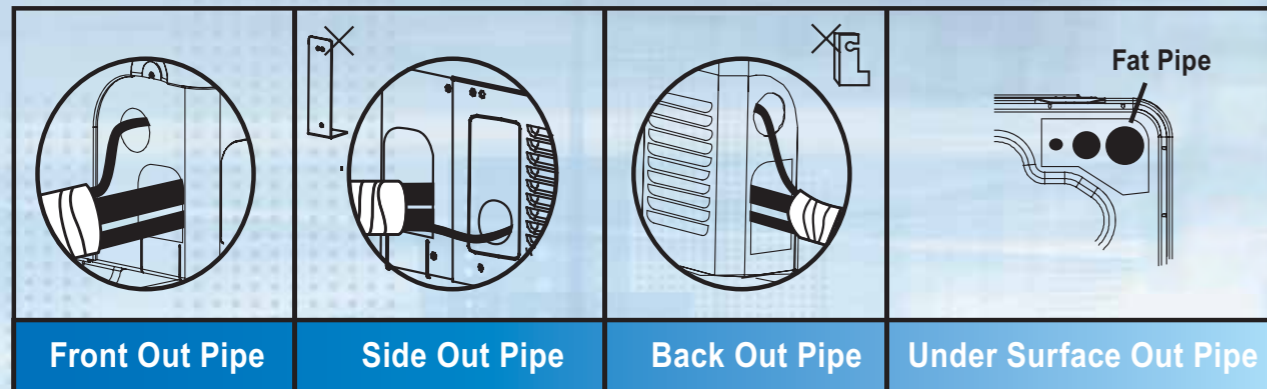
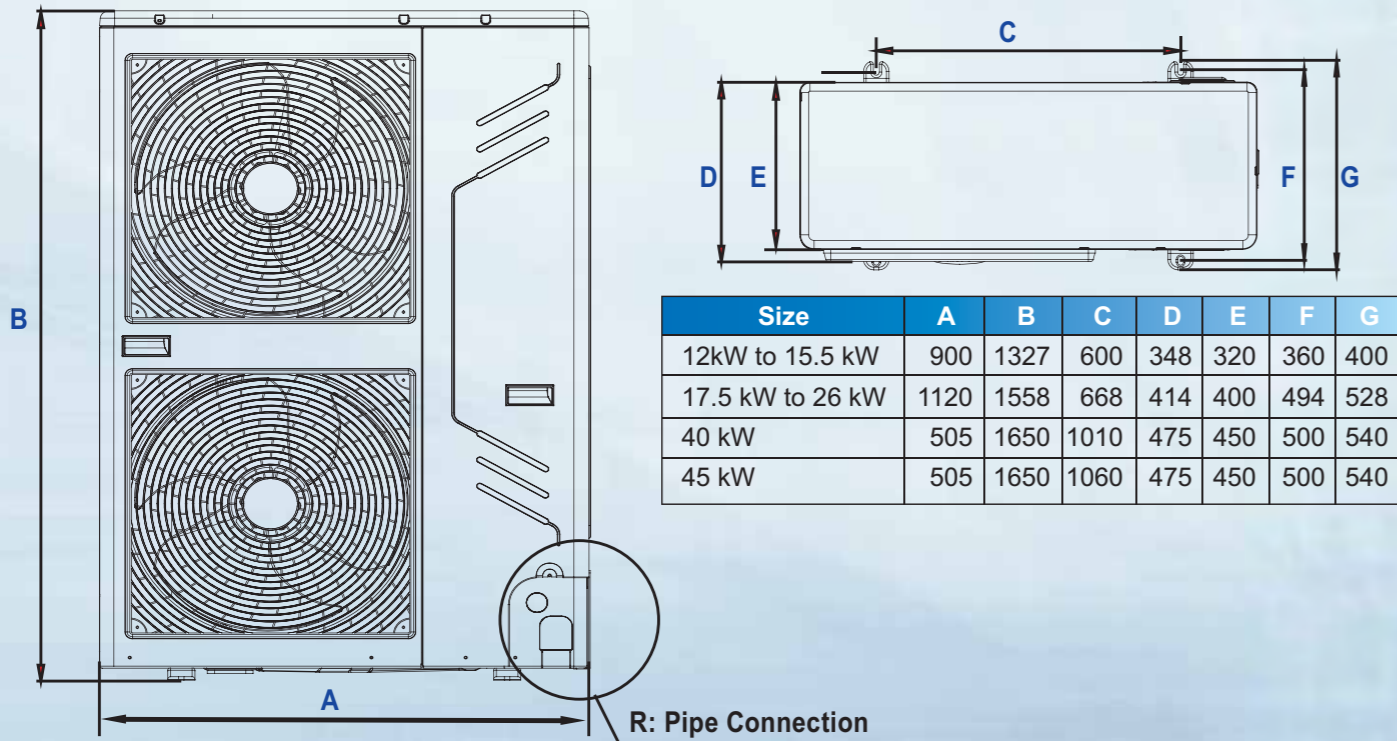

XPOWER Flexi Indoor Units



Indoor Units Lineup

- Cassette One-way 40VZ Series
- Cassette Two-way 40VT Series
- Cassette Compact Four-way 40VX Series
- Cassette Four-way 40VK Series
- Low Static Pressure Ducted 42VD - H112002011 Series
- Medium Static Pressure Ducted 42VD - H112013011 Series
- Medium Static Pressure Ducted 42VD - H112003010 Series
- High Static Pressure Ducted 42VD - H112011010 Series
- High Wall S Type 42VH - 112000101 Series
- High Wall R Type 42VH - 112000102 Series
- Floor / Under - Ceiling 42VF Series
- Console 42VC Series
- Floor Standing 42VS Series
- Fresh Air-processing Unit 42VD - H112211010 Series
- AHU Kit

INDOOR UNITS LINEUP

Type	Model (capacity *100w)	18	22	28	36	45	56	71	80	90	100	112	125	140	160	200	250	280	400	450	560		
		One-way cassette	 Water pump is standard.	▲	▲	▲	▲	▲	▲	▲													
Two-way cassette	 Water pump is standard.		▲	▲	▲	▲	▲	▲															
Compact four-way cassette	 Water pump is standard.		▲	▲	▲	▲																	
Four-way cassette	 Water pump is standard.			▲	▲	▲	▲	▲	▲	▲	▲	▲	▲	▲	▲								
Low Static Pressure Ducted		▲	▲	▲	▲	▲	▲	▲															
Medium Static Pressure Ducted	 Water pump is standard.								▲	▲	▲	▲	▲	▲									
	 (V type) Water pump is standard		▲	▲	▲	▲	▲	▲															
High Static Pressure Ducted							▲	▲	▲		▲												
													▲	▲									
																▲	▲	▲					
																					▲*	▲*	▲*
High Wall S Type		▲	▲	▲	▲	▲																	
High Wall R Type								▲	▲	▲													
Floor & Ceiling				▲	▲	▲	▲	▲	▲	▲	▲	▲	▲	▲	▲								
Console		▲	▲	▲	▲																		
Floor standing		▲	▲	▲	▲	▲	▲	▲															
		▲	▲	▲	▲	▲	▲	▲															
Fresh Air processing unit												▲	▲										
																▲	▲	▲					
AHU Kit														▲				▲					▲

▲ water pump is standard

VRF CASSETTE INDOOR UNITS

VRF Cassette indoor unit is the optimum air conditioning solution for applications which require ceiling installation above false ceiling, elegant appearance and ultimate comfort combined with efficient and quiet operation, optimum air distribution and efficient Indoor Air Quality (IAQ) and environmentally friendly HFC refrigerant R410A.

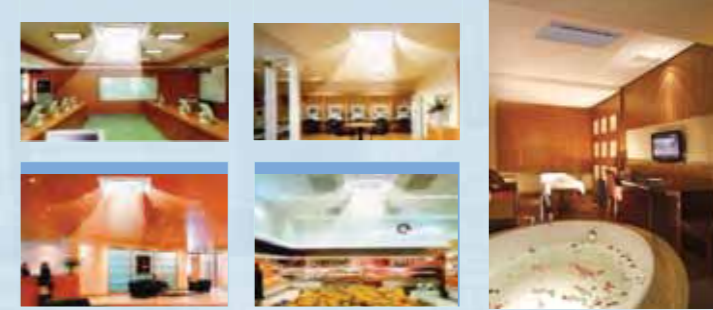

VRF Cassette One-way



1.8 ~ 7.1 kW Cooling
2.2 ~ 8.0 kW Heating

40VZ-H11200011

Model	005	006	009	012	018	024	028
Cooling Capacity	1.8 kW	2.2 kW	2.8 kW	3.6 kW	4.5 kW	5.6 kW	7.1 kW
Heating Capacity	2.2 kW	2.6 kW	3.2 kW	4.0 kW	5.0 kW	6.3 kW	8.0 kW

VRF Cassette Two-way



2.2 ~ 7.1 kW Cooling
2.6 ~ 8.0 kW Heating

40VT-H10200010

Model	006	009	012	018	024	028
Cooling Capacity	2.2 kW	2.8 kW	3.6 kW	4.5 kW	5.6 kW	7.1 kW
Heating Capacity	2.6 kW	3.2 kW	4.0 kW	5.0 kW	6.3 kW	8.0 kW

VRF Cassette Compact Four-way



2.2 ~ 4.5 kW Cooling
2.4 ~ 5.0 kW Heating

40VX-H11200010

Model	006	009	012	018
Cooling Capacity	2.2 kW	2.8 kW	3.6 kW	4.5 kW
Heating Capacity	2.4 kW	3.2 kW	4.0 kW	5.0 kW

VRF Cassette Four-way



2.8 ~ 14 kW Cooling
3.2 ~ 15 kW Heating

40VK-H11200011

Model	009	012	018	024	028
Cooling Capacity	2.8 kW	3.6 kW	4.5 kW	5.6 kW	7.1 kW
Heating Capacity	3.2 kW	4.0 kW	5.0 kW	6.3 kW	8.0 kW

Model	032	036	040	048	056
Cooling Capacity	8.0 kW	9.0 kW	10.0 kW	11.2 kW	14.0 kW
Heating Capacity	9.0 kW	10.0 kW	11.0 kW	12.5 kW	15.0 kW

VRF Cassette - One Way 40VZ Series

1.8 ~ 7.1 kW Cooling

2.2 ~ 8.0 kW Heating



- Auto Restart
- Auto Addressing
- Wireless Controller
- LED Display
- Wired Controller
- Follow Me
- Fresh Air
- Cleanable Panel
- Anti-Cold Air Function
- Built-in Drain Pump
- Super High Air Flow



Auto swing mechanism guarantees even distribution of airflow and better balance of room temperature.

Height 189 mm only

Compact design, ultra slim body with a min. height of 153mm only or 189mm only, especially suitable for narrow ceiling places, such as lobby, small-size meeting room, etc.

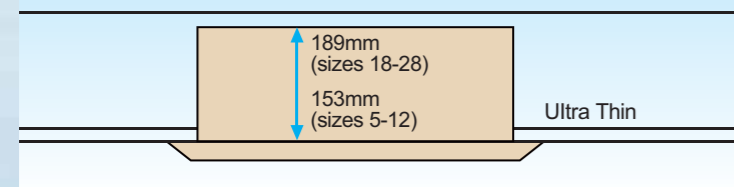

Standard built-in drain pump

Standard built-in drain pump with 750mm pumphead and slim body makes the installation free from limitation of story height.

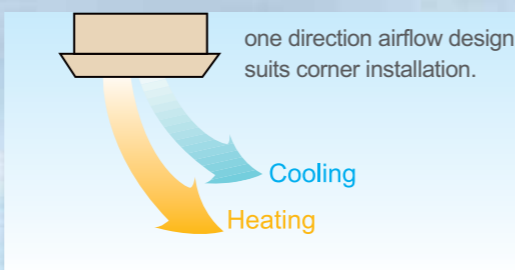
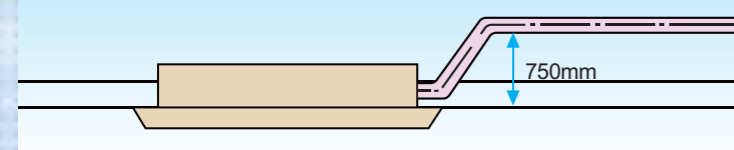

Fresh air, improved air quality

Reserved fresh air intake port for high quality air supply requirement, create a comfort and healthy environment.

Special enzyme sterilization and filtering technology can filter the bacteria, smog, pollen, etc. Provide plenty clean, healthy and natural air supply.

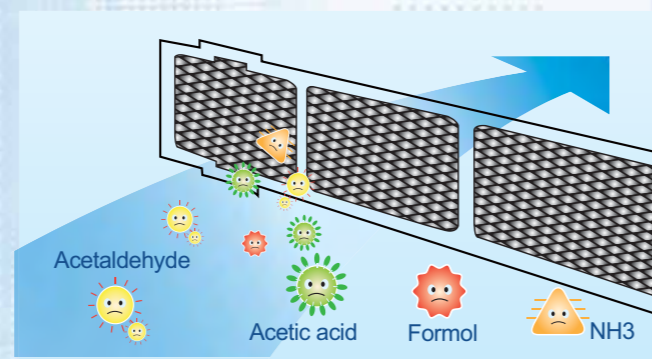

Part names

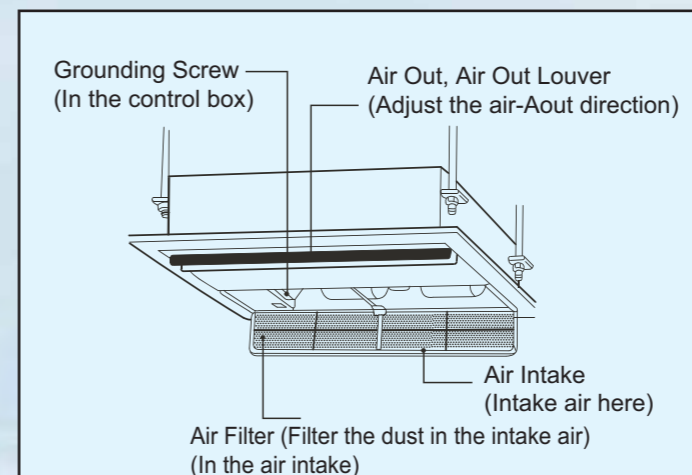

One-way cassette type

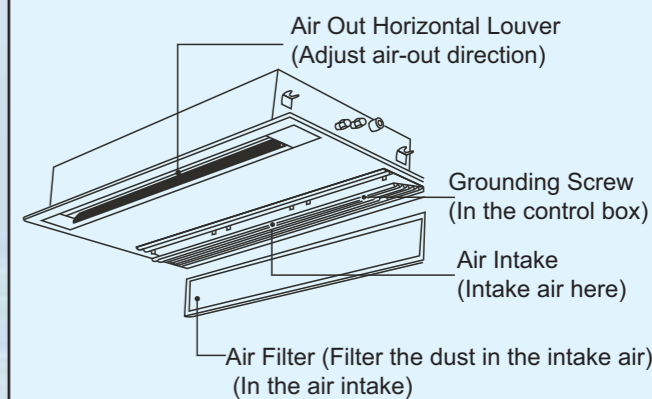

Smart controls

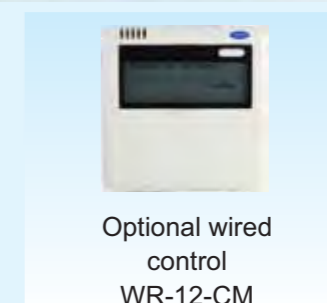

Smart wireless remote controller or optional wired controller with smart, complete control and safety function built in the control systems.

Smart supply airflow

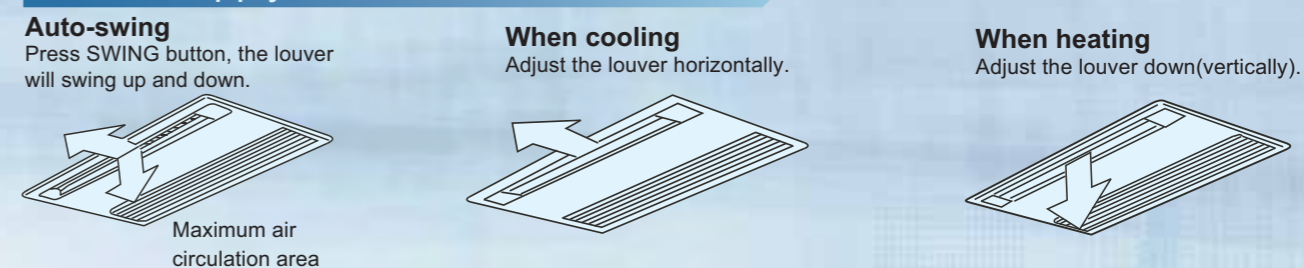

Easy service & maintenance

■ Easy removal of air filters for cleaning

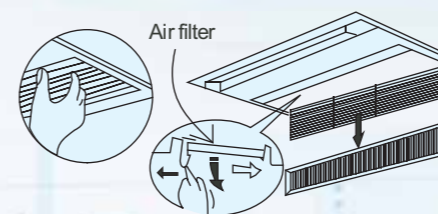

- Easy access to indoor unit components
- Remote on / off function and alarm function

40VZ Series



■ Technical Specifications

Model		40VZ005H11200011	40VZ006H11200011	40VZ009H11200011	40VZ012H11200011
Panel		40VZ00A02	40VZ00A02	40VZ00A02	40VZ00A02
Power supply	V-Ph-Hz	220~240-1-50			
Cooling Capacity	Kw	1.8	2.2	2.8	3.6
	Btu/h	6140	7500	9550	12280
Heating Capacity	Kw	2.2	2.6	3.2	4
	Btu/h	7500	8870	10920	13650
Indoor air flow (H/M/L)	cfm	308/238/162		337/268/185	
Indoor sound level (Hi/Mid/Lo)	dB(A)	37/34/30	38/34/30	39/37/34	40/38/34
Indoor unit	Dimension (WxHxD)	mm 1054 x 153 x 425			
	Packing (WxHxD)	mm 1155 x 245 x 490			
	Net/Gross weight	kg 12.5 / 16		kg 13 / 16.5	
Panel	Dimension (WxHxD)	mm 1180 / 36.5 / 465			
	Packing (WxHxD)	mm 1232 / 107 / 517			
	Net/Gross weight	kg 3.5 / 5.2			
Refrigerant type		R410A			
Refrigerant control	Type	EXV (built-in)			
Refrigerant piping	Liquid side/Gas side	mm Φ 6.35/ Φ 12.7			
Drainage water pipe diameter	mm	Φ 25			
Operation temperature	°C	18 ~ 30			

40VZ Series



■ Technical Specifications

Model		40VZ018H11200011	40VZ024H11200011	40VZ028H11200011
Panel		40VZ00A03	40VZ00A03	40VZ00A03
Power supply	V-Ph-Hz	220~240-1-50		
Cooling Capacity	Kw	4.5	5.6	7.1
	Btu/h	15400	19100	24200
Heating Capacity	Kw	5	6.3	8
	Btu/h	17100	21500	27300
Indoor air flow (H/M/L)	cfm	408/353/280	466/405/323	549/441/349
Indoor sound level (Hi/Mid/Lo)	dB(A)	41/39/35	42/40/36	44/41/37
Indoor unit	Dimension (WxHxD)	mm 1204 x 189 x 443		
	Packing (WxHxD)	mm 1370 x 295 x 505		
	Net/Gross weight	kg 18.5/23.2	kg 18.8/23.5	kg 19.5/24.2
Panel	Dimension (WxHxD)	mm 1350 x 25 x 505		
	Packing (WxHxD)	mm 1410 x 95 x 560		
	Net/Gross weight	kg 4/5.4		
Refrigerant type		R410A		
Refrigerant control	Type	EXV (built-in)		
Refrigerant piping	Liquid side/Gas side	mm Φ 6.35/ Φ 12.7	mm Φ 12.7/ Φ 15.9	
Drainage water pipe diameter	mm	Φ 25		
Operation temperature	°C	18 ~ 30		

VRF Cassette - Two Way 40VT Series

2.2 ~ 7.1 kW Cooling

2.6 ~ 8.0 kW Heating



Super quiet operation

Optimized airflow duct with low resistance makes noise level get reduced greatly, min. 24 dB(A).

Stylish design and slim body

Thanks to the stylish appearance and slim body, the unit can be harmonious with the room decoration and ambient. Slim body with only 300 mm height needs small suspended ceiling space. Installation is free of story height limitation which makes the decoration much more flexible.

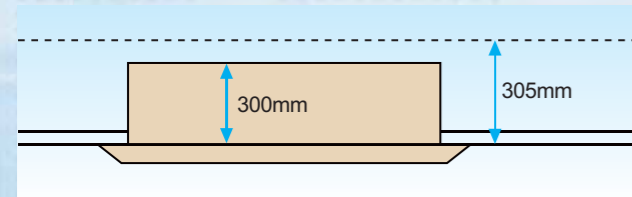

Standard built-in drain pump

Standard built-in drain pump with 750mm pumphead (higher pumphead can be customized).

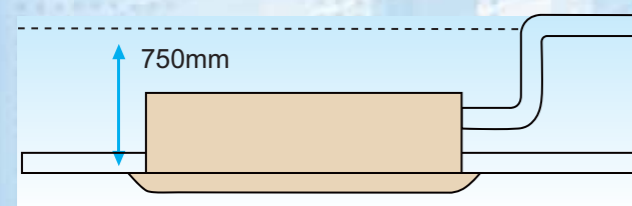

Flat-type suction grille design makes maintenance work very easy.

High airflow

High airflow for high ceiling application guarantees equal comfort of large space. It makes every corner of the room get even distribution of airflow and temperature.



Part names

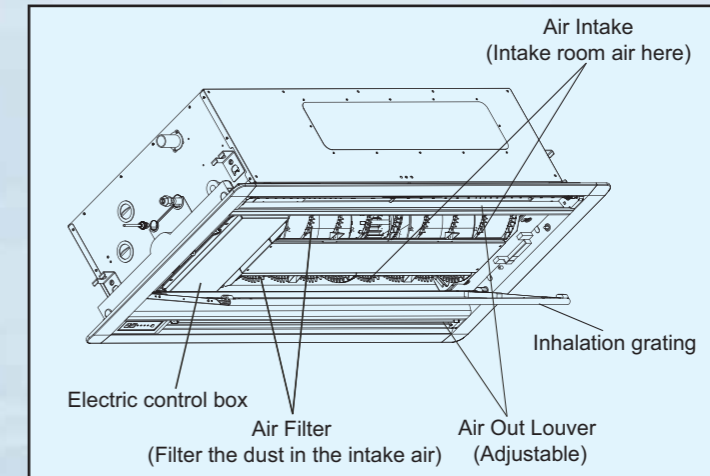

Smart controls



Smart wireless remote controller or optional wired controller with smart, complete control and safety function built in the control systems.

Smart supply airflow

Auto-swing

Press SWING button, the louver will swing up and down.

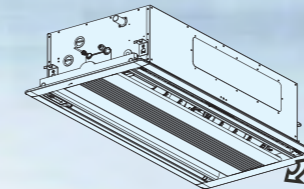

When cooling

Adjust the louver horizontally.



When heating

Adjust the louver down (vertically).



Easy service & maintenance

- Easy removal of air filters for cleaning

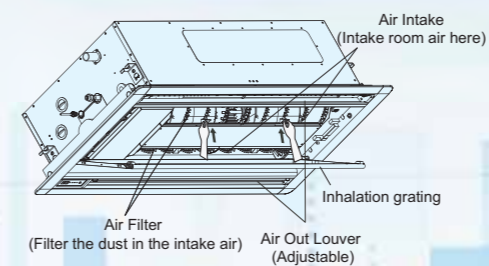

- Easy access to indoor unit components
- Remote on / off function and alarm function

40VT Series



■ Technical Specifications

Model			40VT006H10200010	40VT009H10200010	40VT012H10200010
Power supply		V-Ph-Hz	220-240V-1Ph-50Hz		
Cooling	Capacity	kW	2.2	2.8	3.6
		Btu/h	7,500	9,500	12,200
	Input power	W	65	65	65
	Rated current	A	0.35	0.45	0.45
Heating	Capacity	kW	2.6	3.2	4
		Btu/h	8,900	10,900	13,600
	Input power	W	65	65	65
	Rated current	A	0.35	0.45	0.45
Indoor air flow (H/M/L)		cfm	385/312/241	385/312/241	427/348/270
Indoor sound level (Hi/Mid/Lo)		dB(A)	33/29/24	36/32/29	36/32/29
Indoor unit	Dimension (WxHxD)	mm	1172x300x592	1172x300x592	1172x300x592
	Packing (WxHxD)	mm	1355x400x675	1355x400x675	1355x400x675
	Net/Gross weight	kg	33/42	33/42	33/42
Panel	Model		CE-MBQ2-01 (MBQ2-01)	CE-MBQ2-01 (MBQ2-01)	CE-MBQ2-01 (MBQ2-01)
	Dimension (WxHxD)	mm	1430x90x680	1430x90x680	1430x90x680
	Packing (WxHxD)	mm	1525x130x765	1525x130x765	1525x130x765
	Net/Gross weight	kg	10.5/15	10.5/15	10.5/15
Refrigerant type			R410A	R410A	R410A
Refrigerant control		Type	Electronic expansive valve		
Refrigerant piping	Liquid side/Gas side	mm	Φ6.35/Φ12.7		
Connecting wiring	Signal wiring	Nb×mm ²	3×0.75		
Drainage water pipe diameter		mm	IDΦ25 / ODΦ32		
Standard Controller			Wireless remote controller		
Optional controller			Wired controller WR-12-CM		
Operation temperature		°C	Cooling : 18 ~ 30 Heating : 10 ~ 28		

40VT Series



■ Technical Specifications

Model			40VT018H10200010	40VT024H10200010	40VT028H10200010
Power supply		V-Ph-Hz	220-240V-1Ph-50Hz		
Cooling	Capacity	kW	4.5	5.6	7.1
		Btu/h	15,300	19,100	24,200
	Input power	W	97	112	153
	Rated current	A	0.55	0.55	0.75
Heating	Capacity	kW	5	6.3	8
		Btu/h	17,000	21,500	27,300
	Input power	W	97	112	153
	Rated current	A	0.55	0.55	0.75
Indoor air flow (H/M/L)		cfm	500/394/324	577/471/394	706/589/4531
Indoor sound level (Hi/Mid/Lo)		dB(A)	39/35/30	39/35/30	44/40/34
Indoor unit	Dimension (WxHxD)	mm	1172x300x592	1172x300x592	1172x300x592
	Packing (WxHxD)	mm	1355x400x675	1355x400x675	1355x400x675
	Net/Gross weight	kg	35/44	35/44	35/44
Panel	Model		CE-MBQ2-01 (MBQ2-01)	CE-MBQ2-01 (MBQ2-01)	CE-MBQ2-01 (MBQ2-01)
	Dimension (WxHxD)	mm	1430x90x680	1430x90x680	1430x90x680
	Packing (WxHxD)	mm	1525x130x765	1525x130x765	1525x130x765
	Net/Gross weight	kg	10.5/15	10.5/15	10.5/15
Refrigerant type			R410A	R410A	R410A
Refrigerant control		Type	Electronic expansive valve		
Refrigerant piping	Liquid side/Gas side	mm	Φ6.35/Φ12.7	Φ9.53/Φ15.9	Φ9.53/Φ15.9
Connecting wiring	Signal wiring	Nb×mm ²	3×0.75		
Drainage water pipe diameter		mm	ID Φ25 / OD Φ32		
Standard Controller			Wireless remote controller		
Optional controller			Wired controller WR-12-CM		
Operation temperature		°C	Cooling : 18 ~ 30 Heating : 10 ~ 28		

VRF Cassette Compact - Four Way 40VX Series

2.2 ~ 4.5 kW Cooling

2.4 ~ 5.0 kW Heating



- Auto Restart
- Fresh Air
- Auto Addressing
- Cleanable Panel
- Built-in Drain Pump
- Anti-Cold Air Function
- Wireless Controller
- LED Display
- Wired Controller
- Follow Me
- Super High Air Flow

Compact design, easy installation, service and maintenance

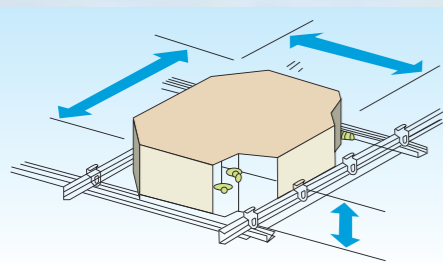

Extremely compact casing (575mm in width and 260mm in depth) makes it perfectly match with the ambient decoration. Little space is required for installation into a shallow ceiling. Due to its compact body and light weight, all models can be installed without a hoist.

Quiet operation, soft air supply

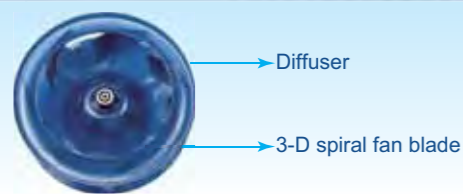

Streamline plate ensures quietness
Advanced 3-D spiral fan design reduces the air resistance and operation noise.

Uniform air flow of four ways



The four air discharge port provides strong circulating air flow to cool or heat every corner of the room and realizes even temperature distribution; by choosing high airflow mode, high ceiling application over 3m can get equal comfort.

360° Airflow outlet



360°air outlet provides strong circulating air flow to cool or heat every corner of the room and realizes even temperature distribution

Standard built-in drain pump

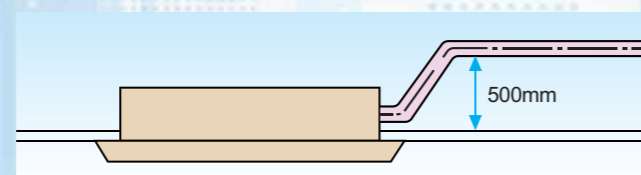

Drain up pump with 500mm pumphead fitted as standard, max. up to 600mm head.

Part names

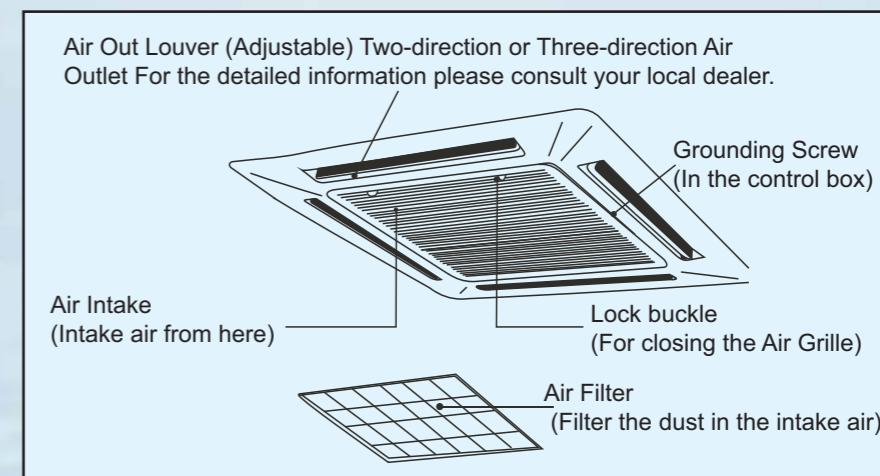

Smart controls



Standard wireless remote control
WL-12-CM



Optional wired control
WR-12-CM

Smart wireless remote controller or optional wired controller with smart, complete control and safety function built in the control systems.

Smart supply airflow

Cooling operation
Adjust the louver horizontally.



Heating operation
Adjust the louver down.



Easy service & maintenance

- Easy removal of air filters for cleaning

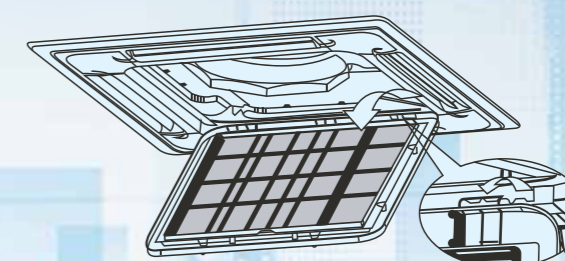
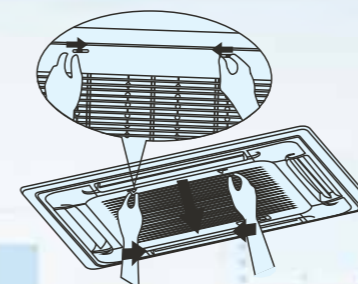

- Easy access to indoor unit components
- Remote on / off function and alarm function

40VX Series



■ Technical Specifications

Model			40VX006H11200010	40VX009H11200010
Power supply		V-ph-Hz	220~240-1Ph-50Hz	
Cooling	Capacity	kW	2.2	2.82
		Btu/h	7,500	9,500
	Input power	W	50	50
	Rated current	A	0.175	0.175
Heating	Capacity	kW	2.4	3.2
		Btu/h	8,900	10,900
	Input power	W	42	42
	Rated current	A	0.175	0.175
Indoor air flow (Hi/Mi/Lo)		cfm	308/244/185	
Sound level (H/M/L)		dB(A)	35.8/33.4/23.4	
Indoor unit	Dimension(W x H x D)	mm	630x260x570	
	Packing(W x H x D)	mm	675x285x575	
	Net/Gross weight	kg	16/20	
Panel	Dimension(W x H x D)	mm	647x50x647	
	Packing(W x H x D)	mm	715x123x715	
	Net/Gross weight	kg	2.5 / 4.5	
Refrigerant Type			R410A	R410A
Refrigerant piping	Liquid side/Gas side	mm	6.35/12.7	
Connection wiring	Signal wiring	mm ²	3*0.5 (3-core shielded wire)	
Drainage water pipe diameter		mm	ID Φ20 / ODΦ25	
Standard Controller			Wireless remote controller	
Optional controller			Wired controller WR-12-CM	
Operation temperature		°C	Cooling: 18~30 Heating: 10~28	

40VX Series



■ Technical Specifications

Model			40VX012H11200010	40VX018H11200010
Power supply		V-ph-Hz	220~240-1Ph-50Hz	
Cooling	Capacity	kW	3.6	4.5
		Btu/h	12,200	15,300
	Input power	W	58	58
	Rated current	A	0.21	0.21
Heating	Capacity	kW	4	5
		Btu/h	13,600	17,000
	Input power	W	50	50
	Rated current	A	0.21	0.21
Indoor air flow (Hi/Mi/Lo)		cfm	360 / 307 / 241	
Sound level (H/M/L)		dB(A)	41.5 / 35.6 / 28.8	
Indoor unit	Dimension (WxHxD)	mm	630x260x570	
	Packing (WxHxD)	mm	675 x 285 x 675	
	Net/Gross weight	kg	18 / 22	
Panel	Dimension (WxHxD)	mm	647 x 50 x 647	
	Packing (WxHxD)	mm	715 x 123 x 715	
	Net/Gross weight	kg	2.5 / 4.5	
Refrigerant Type			R410A	R410A
Refrigerant piping	Liquid side/Gas side	mm	6.35/12.7	
Connection wiring	Signal wiring	mm ²	3*0.75 (3-core shielded wire)	
Drainage water pipe diameter		mm	IDΦ20 / ODΦ25	
Standard Controller			Wireless remote controller	
Optional controller			Wired controller WR-12-CM	
Operation temperature		°C	Cooling : 18~30 Heating : 10~28	

VRF Cassette - Four Way 40VK Series

2.8 ~ 14 kW Cooling

3.2 ~ 15 kW Heating



- | | |
|---------------------|------------------------|
| Auto Restart | Fresh Air |
| Auto Addressing | Cleanable Panel |
| Built-in Drain Pump | Anti-Cold Air Function |
| LED Display | Wireless Controller |
| Wired Controller | Super High Air Flow |
| Follow Me | |

Uniform air flow of four ways

The four air discharge port provides strong circulating air flow to cool or heat every corner of the room and realizes even temperature distribution; by choosing high airflow mode, high ceiling application over 3m can get equal comfort.

Four-way Airflow(4-stage fan speed)

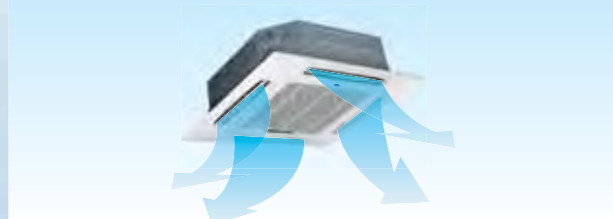

Panel available

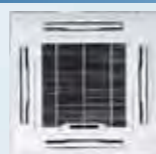

(White)
Standard

Quiet operation, soft air supply

- Streamline plate ensures quietness
- Advanced 3-D spiral fan design reduces the air resistance and operation noise.



Reserved multi-function ports

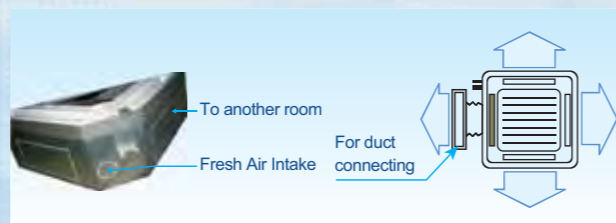

Slim compact design

Slim ultra-thin Slim compact design for easy installation, service and maintenance.
Height is only 230mm for sizes 012-018-024-028-032
Height is only 300mm for sizes 036-040-048-056

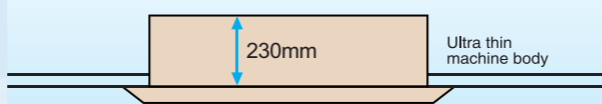

Part names

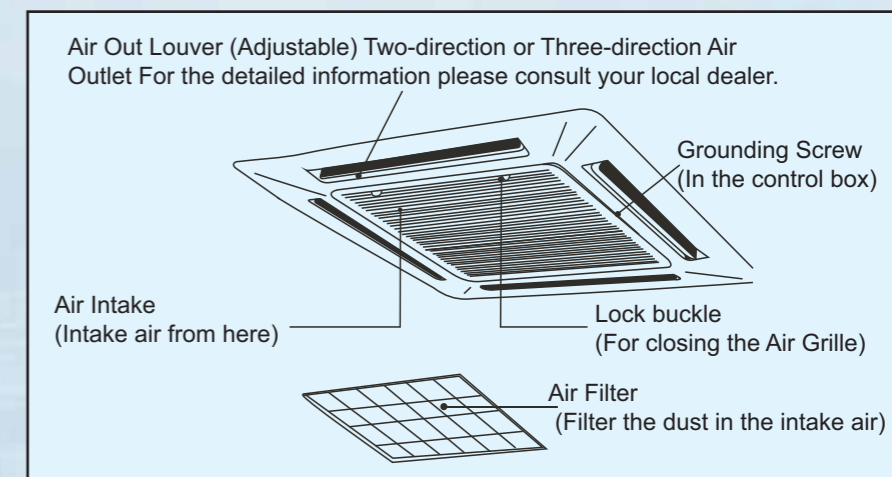

Smart controls



Standard wireless remote control
WL-12-CM



Optional wired control
WR-12-CM

Smart wireless remote controller or optional wired controller with smart, complete control and safety function built in the control systems.

Smart supply airflow

Cooling operation
Adjust the louver horizontally.



Heating operation
Adjust the louver down.



Easy service & maintenance

- Easy removal of air filters for cleaning



- Easy access to indoor unit components
- Remote on / off function and alarm function

40VK Series



■ Technical Specifications

Model			40VK009H11200011	40VK012H11200011	40VK018H11200011	40VK024H11200011	40VK028H11200011
Power Supply		V-Ph-Hz	220~240V-1Ph-50Hz				
Cooling	Capacity	kW	2.8	3.6	4.5	5.6	7.1
		Btu/h	9500	12200	15300	19100	24200
	Power Input	W	80	80	80	80	80
Heating	Capacity	kW	3.2	4	5	6.3	8
		Btu/h	10900	13600	17000	21500	27300
	Power Input	W	80	80	80	80	80
Indoor air flow (H/M/L)		CFM	450/376/326	450/376/326	533/436/383	533/436/383	560/452/391
Sound pressure level (H/M/L)		dB(A)	32/31/30	32/31/30	36/35/34	36/35/34	39/37/36
Indoor unit body	Net dimension (WxHxD)	mm	840x230x840				
	Packing size (WxHxD)	mm	955x260x955				
	Net/Gross weight	kg	21.5/26.7		23.7/28.9		
Indoor unit panel	Model		T-MBQ4-02B1				
	Net dimension (WxHxD)	mm	950x54x 950				
	Packing size (WxHxD)	mm	1035x90x1035				
	Net/Gross weight	kg	6/9				
Refrigerant			R410A				
Refrigerant Control		Type	Electronic Expansion valve				
Refrigerant Pipe	Liquid pipe	mm	Φ6.35			Φ9.53	
	Gas pipe	mm	Φ12.7			Φ15.9	
Connecting Wiring	Single Wiring	NbXmm ²	3 x 0.75	3 x 0.75	3 x 0.75	3 x 0.75	3 x 0.75
Drain pipe diameter			IDΦ28.5 / ODΦ32				
Standard Controller			Wireless remote controller (WL-12-CM)				
Optional Controller		MPa	Wired remote controller				

40VK Series



■ Technical Specifications

Model			40VK032H11200011	40VK036H11200011	40VK040H11200011	40VK048H11200011	40VK056H11200011
Power Supply		V-Ph-Hz	220~240V-1Ph-50Hz				
Cooling	Capacity	kW	8	9	10	11.2	14
		Btu/h	27300	30700	34100	38200	47800
	Power Input	W	100	130	150	150	160
Heating	Capacity	kW	9	10	11.1	12.5	16
		Btu/h	30700	34100	37500	42600	51200
	Power Input	W	100	130	150	150	160
Indoor air flow (H/M/L)		CFM	707/601/465	785/665/535	972/768/664	972/768/664	977/786/664
Sound pressure level (H/M/L)		dB(A)	43/40/38	43/40/38	46/42/40	46/42/40	46/42/40
Indoor unit body	Net dimension (WxHxD)	mm	840x230x840	840x300x840			
	Packing size (WxHxD)	mm	955x260x955	955x330x955			
	Net/Gross weight	kg	23.7/28.9	28.7/34.1			30.9/36.3
Indoor unit panel	Model		T-MBQ4-02B1				
	Net dimension (WxHxD)	mm	950x54x 950				
	Packing size (WxHxD)	mm	1035x90x1035				
	Net/Gross weight	kg	6/9				
Refrigerant			R410A				
Refrigerant Control		Type	Electronic Expansion valve				
Refrigerant Pipe	Liquid pipe	mm	Φ9.53				
	Gas pipe	mm	Φ15.9				
Connecting Wiring	Single Wiring	NbXmm ²	3 x 0.75	3 x 0.75	3 x 0.75	3 x 0.75	3 x 0.75
Drain pipe diameter			IDΦ28.5 / ODΦ32				
Standard Controller			Wireless remote controller (WL-12-CM)				
Optional Controller		MPa	Wired remote controller				

VRF DUCTED INDOOR UNITS

VRF Ducted indoor unit is the optimum air conditioning solution for places which require ceiling installation above false ceiling and also require medium static pressure, optimum air distribution, increased air throw distance, minimum sound levels and environmentally friendly HFC refrigerant R410A.



VRF Ducted Low Static Pressure



1.8 ~ 7.1 kW Cooling
2.2 ~ 8.0 kW Heating

42VD-H112002011

Model	005	006	009	012	018	024	028
Cooling Capacity	1.8 kW	2.2 kW	2.8 kW	3.6 kW	4.5 kW	5.6 kW	7.1 kW
Heating Capacity	2.2 kW	2.6 kW	3.2 kW	4.0 kW	5.0 kW	6.3 kW	8.0 kW

VRF Ducted High Static Pressure

7.1 ~ 11.2 kW Cooling
8.0 ~ 12.5 kW Heating

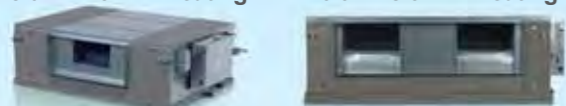

14.0 ~ 16.0 kW Cooling
16.0 ~ 18.0 kW Heating



20.0 ~ 28.0 kW Cooling
22.5 ~ 31.5 kW Heating

Model	028	032	036	048
Cooling Capacity	7.1 kW	8.0 kW	9.0 kW	11.2 kW
Heating Capacity	8.0 kW	9.0 kW	10.0 kW	12.5 kW

Model	054	055	056	058	060
Cooling Capacity	14.0 kW	16.0 kW	20.0 kW	25.0 kW	28.0 kW
Heating Capacity	16.0 kW	18.0 kW	22.5 kW	26.0 kW	31.5 kW

VRF Ducted Medium Static Pressure

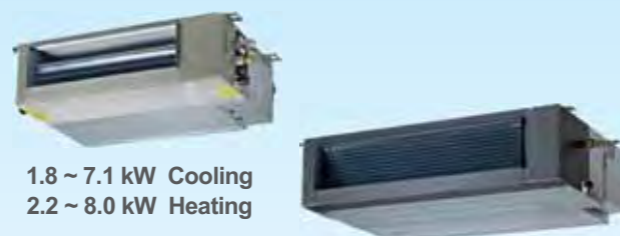

1.8 ~ 7.1 kW Cooling
2.2 ~ 8.0 kW Heating

8 ~ 14.0 kW Cooling
9 ~ 15.5 kW Heating

42VD-H112013011

Model	006	009	012	018	024	028
Cooling Capacity	2.2 kW	2.8 kW	3.6 kW	4.5 kW	5.6 kW	7.1 kW
Heating Capacity	2.4 kW	3.2 kW	4.0 kW	5.0 kW	6.3 kW	8.0 kW

42VD-H112003010

Model	032	036	048	054
Cooling Capacity	8.0 kW	9.0 kW	11.2 kW	14.0 kW
Heating Capacity	9.0 kW	10.0 kW	12.5 kW	15.5 kW

VRF Ducted High Static Pressure



40 ~ 56 kW Cooling
45 ~ 53 kW Heating

42VD-H112011010

Model	140	160	190
Cooling Capacity	40 kW	45 kW	56 kW
Heating Capacity	45 kW	50 kW	53 kW

VRF Ducted Low Static Pressure 42VD-H112002011 Series

1.8 ~ 7.1 kW Cooling
2.2 ~ 8.0 kW Heating



- Auto Restart
- Auto Addressing
- Connectable To Duct
- Wired Controller
- Super High Air Flow
- Anti-Cold Air Function
- Cleanable Panel
- Wireless Controller
- Follow Me

Wide capacity range

From 1.8KW to 7.1KW, seven models.

Low sound level



Utilize the cross blow fan, the lowest sound level is 24dB (A).
Excellent choice for hotels and other sound sensitive places.

More Smooth airflow with less turbulence

Thanks to the multiple-blade fan rotor and the air guide design, the airflow is getting smoother and more comfortable

Convenient installation

The EXV is fixed beside of the indoor unit
Suction chamber is included as stand.ard equipment

Slim, light weight, and compact design

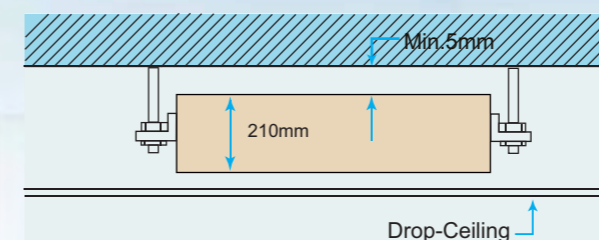

Uniform 210mm in height, compact design for easy installation where space over ceiling is limited,
The whole body adopts fireproof plastic material , the minimum weight is 14kg

Optional drain pump

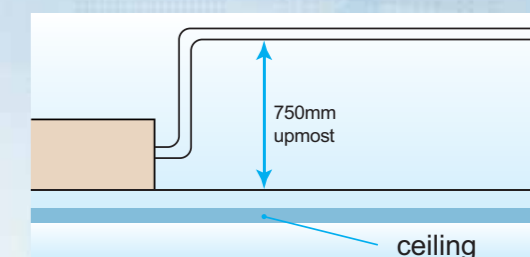

Optional drain-pump (750 mm pumphead).

Part names

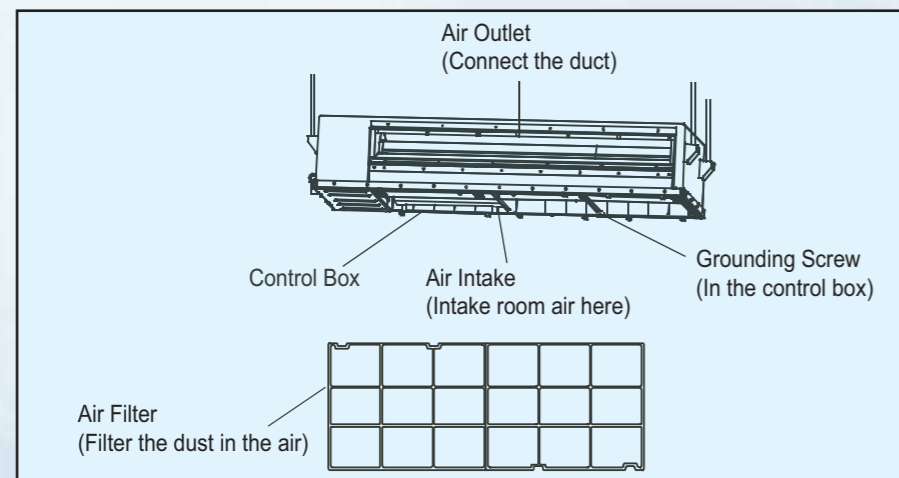

Smart controls

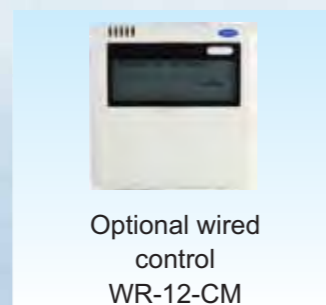

Smart wireless remote controller or optional wired controller with smart, complete control and safety function built in the control systems.

Smart supply airflow

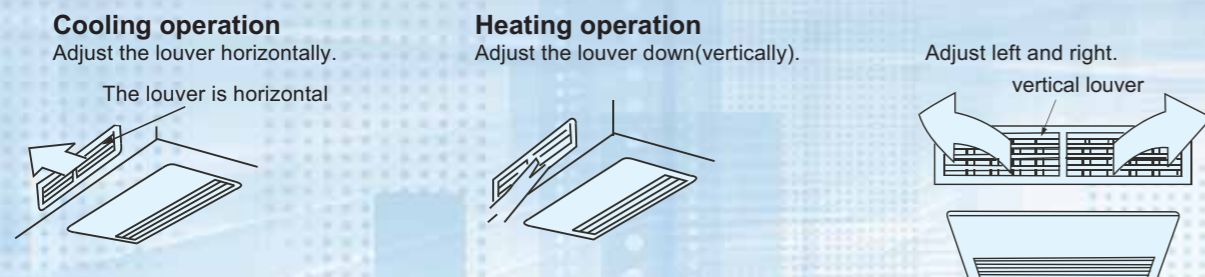

Easy service & maintenance

- Easy removal of air filters for cleaning
- Easy access to indoor unit components
- Remote on / off function and alarm function

42VD H112002011 Series

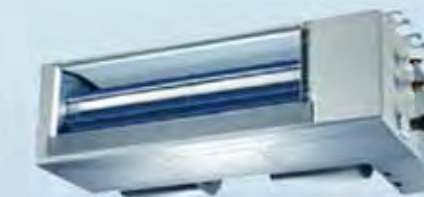

■ Technical Specifications

Model			42VD005H112002011	42VD006H112002011	42VD009H112002011
Power Supply		V-Hz-Ph	220-240V-50Hz-1Ph		
Cooling	Capacity	kW	1.8	2.2	2.8
		Btu/h	6100	7500	9500
	Input	W	65	65	65
Heating	Capacity	kW	2.2	2.6	3.2
		Btu/h	7500	8870	10900
	Input	W	67	67	67
Indoor air flow (H/M/L)		cfm	356/301/240	356/301/240	356/301/240
Indoor external static pressure Std (Min-Max)		Pa	10(10~30)	10(10~30)	10(10~30)
Indoor noise level (H/M/L)		dB(A)	35/27/24	35/27/24	35/27/24
Indoor Unit	Dimension (W*H*D)	mm	740*210*470	740*210*470	740*210*470
	Packing (W*H*D)	mm	910*230*510	910*230*510	910*230*510
	Net/Gross weight	kg	14/17.5	14/17.5	14/17.5
Refrigerant type			R410A	R410A	R410A
Refrigerant Control		Type	EXV	EXV	EXV
Refrigerant piping	Liquid side/Gas side	mm	Φ6.35/Φ12.7	Φ6.35/Φ12.7	Φ6.35/Φ12.7
Connecting wiring	Single wiring	mm ²	3*0.75	3*0.75	3*0.75
Drainage water pipe diameter			ODΦ25	ODΦ25	ODΦ25
Wireless is standard (Wired controller is optional)			Wireless is standard (Wired controller is optional)		

42VD H112002011 Series



■ Technical Specifications

Model		42VD012H112002011	42VD018H112002011	42VD024H112002011	42VD028H112002011	
Power Supply		V-Hz-Ph	220-240V-50Hz-1Ph			
Cooling	Capacity	kW	3.6	4.5	5.6	7.1
		Btu/h	12200	15300	19100	24200
	Input	W	67	85	85	108
Heating	Capacity	kW	4.0	5.0	6.3	8.0
		Btu/h	13600	17000	21500	27300
	Input	W	70	86	86	110
Indoor air flow (H/M/L)		cfm	380/324/260	472/406/358	472/406/358	710/570/477
Indoor external static pressure Std (Min-Max)		Pa	10(10~30)	10(10~30)	10(10~30)	10(10~30)
Indoor noise level (H/M/L)		dB(A)	35/27/24	39/32/29	39/32/29	41/33/30
Indoor Unit	Dimension (W*H*D)	mm	740*210*470	960*210*470	960*210*470	1180*210*470
	Packing (W*H*D)	mm	910*230*510	1130*230*510	1130*230*510	1350*230*510
	Net/Gross weight	kg	14/17.5	18/22.5	18/22.5	21.5/26.5
Refrigerant type			R410A	R410A	R410A	R410A
Refrigerant Control		Type	EXV	EXV	EXV	EXV
Refrigerant piping	Liquid side/Gas side	mm	Φ6.35/Φ12.7	Φ6.35/Φ12.7	Φ9.53/Φ15.9	Φ9.53/Φ15.9
Connecting wiring	Single wiring	mm ²	3*0.75	3*0.75	3*0.75	3*0.75
Drainage water pipe diameter			ODΦ25	ODΦ25	ODΦ25	ODΦ25
Controller			Wireless is standard (Wired controller is optional)			

VRF Ducted Medium Static Pressure 42VD H112013011 Series

2.2 ~ 14.0 kW Cooling

2.6 ~ 15.5 kW Heating

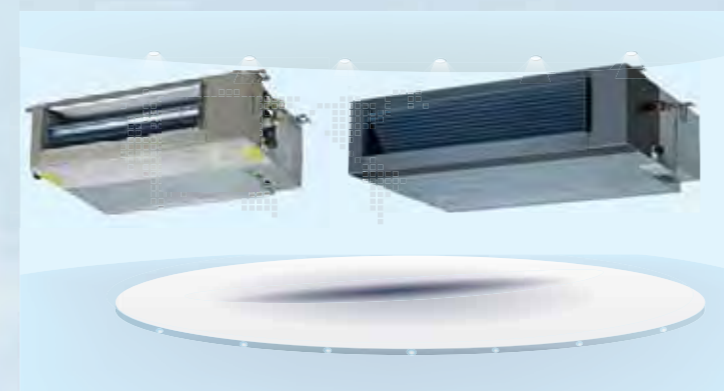
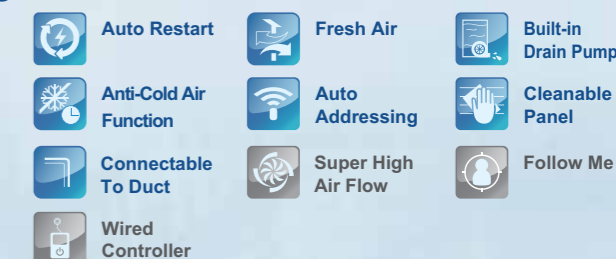

Compact size

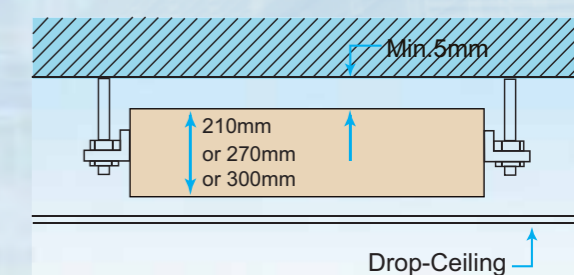

Wide capacity range

The cooling capacity ranges from 2.2KW to 14.0KW, totally 12 models.

- Only 210 mm (005~028 models) or 270mm (032 to 048 model) or 300mm (052 & 054 models) in height.
- The EXV is built-in design of the indoor unit, main body without an extra EXV box.

External static pressure settings for added flexibility

Four speed fan motor (Super high speed is an optional speed)
Exchange the wiring connection of 'SH' and 'Hi' to change the External Static Pressure (ESP).

Easy and flexible installation

- The Electronic Expansion Valve (EXV) is fixed inside of the indoor unit
- Standard air filters placed in an aluminum frame, which is removable downward from bottom.
- Suction chamber is included as standard equipment
- Fresh air hole, air inlet/outlet flange are standard for easy duct connection.
- Return air from back is standard and from bottom as optional with the same connectable duct.

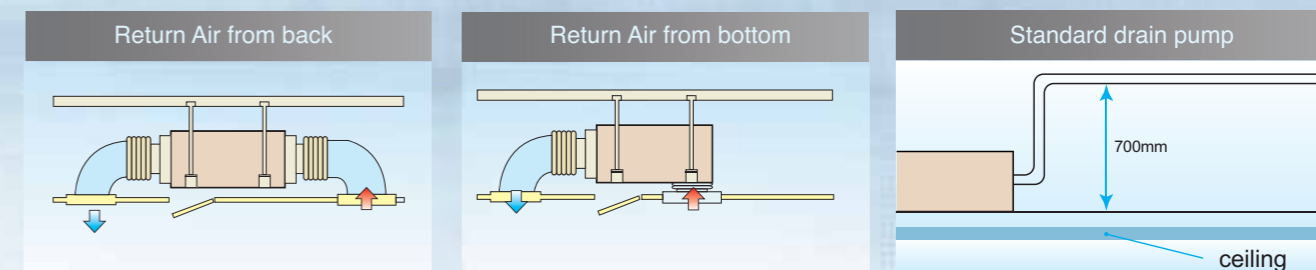

Flexible control and convenient for easy service and maintenance

- The display board is connected with the E-box in factory, easier trouble-shooting by LED display.
- The Electrical control box can be removed 1m away from the unit, easy to access when needs maintenance. (Should be required by client in advance and done in factory)
- Standard functional port such as Remote On/Off Dry contact switch and Alarm signal output (220V)

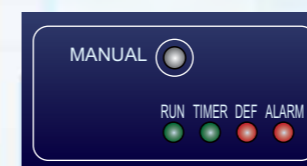

005~024 model

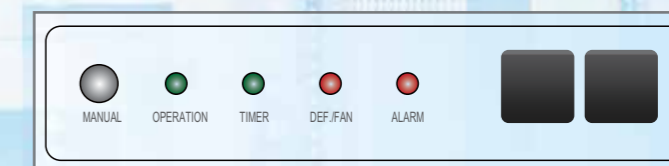

028~054 model

Part names

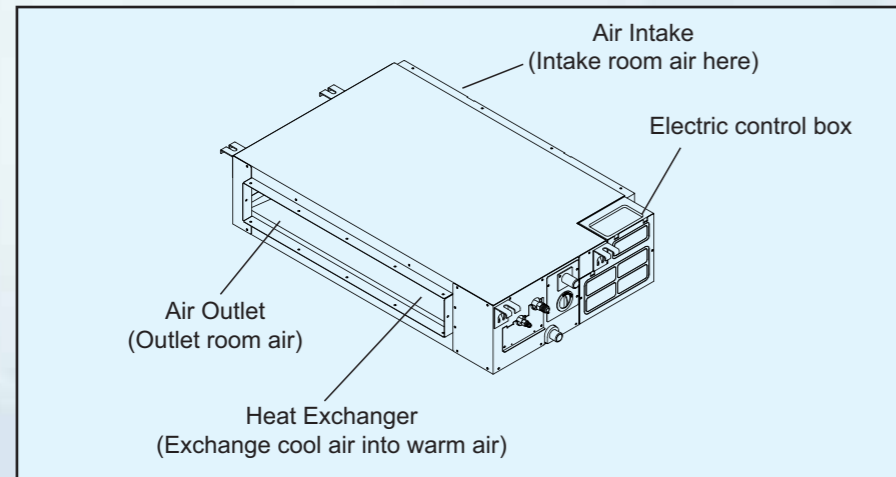

Smart controls

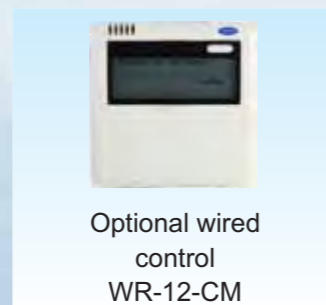

Smart wireless remote controller or optional wired controller with smart, complete control and safety function built in the control systems.

Smart supply airflow

Cooling operation

Adjust the louver horizontally.

The louver is horizontal

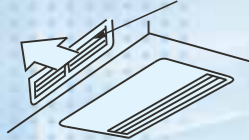

Heating operation

Adjust the louver down(vertically).

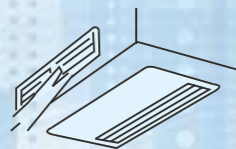

Adjust left and right.

vertical louver

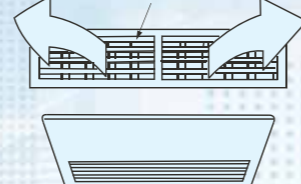

Easy service & maintenance

- Easy removal of air filters for cleaning
- Easy access to indoor unit components
- Remote on / off function and alarm function

42VD H112013011 Series



■ Technical Specifications

Model			42VD006H112013011	42VD009H112013011	42VD012H112013011
Power Supply		V-Hz-Ph	220-240V-50Hz-1Ph		
Cooling	Capacity	kW	2.2	2.8	3.6
		Btu/h	7500	9500	12200
	Input	W	68	68	72
Heating	Capacity	kW	2.6	3.2	4.0
		Btu/h	8900	10900	13600
	Input	W	65	65	69
Indoor air flow (SH/H/M/L)		CFM	346(30pa)/316/268/221	346(30pa)/316/268/221	361(30pa)/351/302/252
Indoor external static pressure Std (Min-Max)		Pa	10(10~30)	10(10~30)	10(10~30)
Indoor noise level (H/M/L)		dB(A)	36/35/32	37/35/32	38.6/37.5/33.8
Indoor Unit	Dimension (W*H*D)	mm	740*210*500	740*210*500	740*210*500
	Packing (W*H*D)	mm	870*285*525	870*285*525	870*285*525
	Net/Gross weight	kg	17.5/20	17.5/20	17.5/20
Fresh Air intake hole diameter (round)		mm	Φ92	Φ92	Φ92
Refrigerant type			R410A	R410A	R410A
Refrigerant Control		Type	EXV	EXV	EXV
Refrigerant piping	Liquid side/Gas side	mm	Φ6.35/Φ12.7	Φ6.35/Φ12.7	Φ6.35/Φ12.7
Connecting wiring	Single wiring	mm ²	3*0.75	3*0.75	3*0.75
Drainage water pipe diameter			ODΦ25	ODΦ25	ODΦ25
Controller			Wireless is standard (Wired controller is optional)		

42VD H112013011 Series



■ Technical Specifications

Model		42VD018H112013011	42VD024H112013011	42VD028H112013011	
Power Supply		V-Hz-Ph	220-240V-50Hz-1Ph		
Cooling	Capacity	kW	4.5	5.6	7.1
		Btu/h	15300	19100	24200
	Input	W	80	80	105
Heating	Capacity	kW	5.0	6.3	8.0
		Btu/h	17000	21500	27300
	Input	W	80	80	105
Indoor air flow (SH/H/M/L)		CFM	488(30pa)/477/402/338	488(30pa)/477/402/338	663(30pa)/605/549/459
Indoor external static pressure Std (Min-Max)		Pa	10(10~30)	10(10~30)	10(10~30)
Indoor noise level (H/M/L)		dB(A)	39/37.9/34	39/37.9/34	41.4/39/35
Indoor Unit	Dimension (W*H*D)	mm	960*210*500	960*210*500	1180*210*500
	Packing (W*H*D)	mm	1115*285*525	1115*285*525	1335*285*525
	Net/Gross weight	kg	22.5/26	22.5/26	28/31.5
Fresh Air intake hole diameter (round)		mm	Φ92	Φ92	Φ92
Refrigerant type			R410A	R410A	R410A
Refrigerant Control		Type	EXV	EXV	EXV
Refrigerant piping	Liquid side/Gas side	mm	Φ6.35/Φ12.7	Φ9.53/Φ15.9	Φ9.53/Φ15.9
Connecting wiring	Single wiring	mm ²	3*0.75	3*0.75	3*0.75
Drainage water pipe diameter			ODΦ25	ODΦ25	ODΦ25
Controller			Wireless is standard (Wired controller is optional)		

42VD H1120130110 Series



■ Technical Specifications

Model		42VD032H112003010	42VD036H112003010	
Power supply		V-ph-Hz	220~240V-1Ph-50Hz	
Cooling	Capacity	kW	8	9
		Btu/h	27,300	30,700
	Input power	W	231	231
Heating	Capacity	kW	9	10
		Btu/h	30,700	34,100
	Input power	W	231	231
Indoor air flow (/Hi/Mi/Lo)		cfm	825(30Pa)/795/687/608	825(30Pa)/795/687/608
Static pressure Std (Min-Max)		Pa	20(10~50)	20(10~50)
Sound level (H/M/L)		dB(A)	45.4/39.8/37	45.4/39.8/37
Indoor unit	Dimension (W x H x D)	mm	1140x270x775	1140x270x775
	Packing (W x H x D)	mm	1355x350x795	1355x350x795
	Net/Gross weight	kg	38/46.5	40/48
Fresh Air intake hole diameter (round)		mm	Φ125	Φ125
Refrigerant Type			R410A	R410A
Refrigerant control		Type	Electronic Expansion Valve	
Refrigerant piping	Liquid side/ Gas side	mm	Φ9.53/Φ15.9	Φ9.53/Φ15.9
Connection wiring	Signal wiring	mm ²	3×0.75	
Drainage water pipe diameter		mm	IDΦ25 / ODΦ32	
Controller			Wireless is standard (Wired controller is optional)	

42VD H112003010 Series



Technical Specifications

Model		42VD048H112003010	42VD052H112003010	42VD054H112003010	
Power supply		V-ph-Hz	220~240V-1Ph-50Hz		
Cooling	Capacity	kW	11.2	12.5	14
		Btu/h	38,200	42,660	47,800
	Input power	W	327	355	355
	Rated current	A	1.8	1.9	1.9
Heating	Capacity	kW	12.5	13.5	15.5
		Btu/h	42,600	46,100	52,900
	Input power	W	327	355	355
	Rated current	A	1.8	1.9	1.9
Indoor air flow (/Hi/Mi/Lo)		cfm	1199 (30Pa)/1059 /921/824	1258 (30Pa)/1118/967/827	1258 (30Pa)/1118/967/827
Static pressure Std (Min-Max)		Pa	40 (10~80)	40 (10~100)	40 (10~100)
Sound level (sound pressure)		dB(A)	48/42/38	48/43/39	48/43/39
Indoor unit	Dimension (W x H x D)	mm	1140 x 270 x 775	1200 x 300 x 865	1200 x 300 x 865
	Packing (W x H x D)	mm	1355 x 350 x 795	1400 x 370 x 925	1400 x 370 x 925
	Net/Gross weight	kg	40/48	49/58	49/58
Fresh Air Intake	Size (round)	mm	Φ125	Φ125	Φ125
Refrigerant Type			R410A	R410A	R410A
Refrigerant control		Type	Electronic Expansion Valve		
Refrigerant piping	Liquid side/ Gas side	mm	Φ9.53/Φ15.9	Φ9.53/Φ15.9	Φ9.53/Φ15.9
Connection wiring	Signal wiring	mm ²	3×0.75		
Drainage water pipe diameter		mm	IDΦ25 / ODΦ32		
Standard Controller			Wireless remote controller		

VRF Ducted High Static Pressure 42VD-H112011010 Series

7.1 ~ 28.0 kW Cooling
8.0 ~ 31.5 kW Heating

- Auto Restart
- Auto Addressing
- Wireless Controller
- Connectable To Duct
- Fresh Air
- Cleanable Panel
- Anti-Cold Air Function
- Wired Controller



Wide capacity range

The capacity ranges from 7.1KW to 56KW, totally 12 models.

Flexible duct design

Four speed fan motor (medium high speed as an option only for 028~055 model)
External static pressure can be up to 196Pa (028~055 models) or 250Pa (056~060 models).

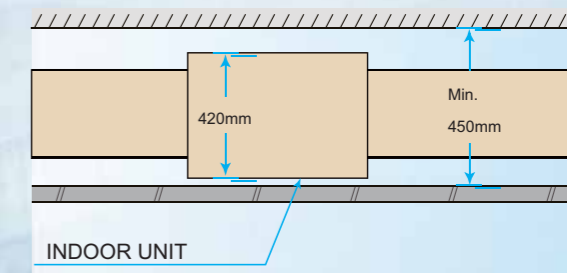
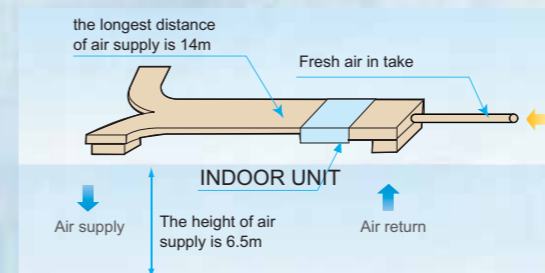

The max distance of air supply is about 14m while the height of air supply is about 6.5m.
With 420mm (028~055 model) thickness body, the minimum distance above the ceiling is 450mm.

Added flexibility with four speed fan

Just exchange the wiring connection of 'MH' and 'Me'.(for 028~055 model)

Easy and flexible installation

- The EXV is fixed inside the indoor unit (for 028~055 model), no need extra connection.
- Standard filter placed in an aluminum frame, which is removable downward from bottom.
- Flange for air in/outlet duct connection is standard.

Flexible control and convenient for easy service and maintenance

- Standard Wired remote controller, and wireless remote controller is as an option.
- The display board is connected with the E-box in factory, easier trouble-shooting by LED display.
- Easy access filters both in rear & bottom
- Standard functional port such as remote on/off dry contact.

Optional drain pump

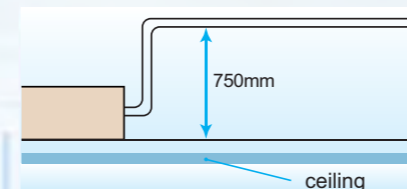

Optional drain pump with 750 mm pumphead.
* (for 028~055 model)

Double-skin drainage pan

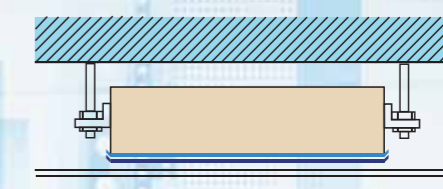

Double-skin drainage pan provide double protection for ceilings (models 71 to 160 and models 400 to 560)

Part names

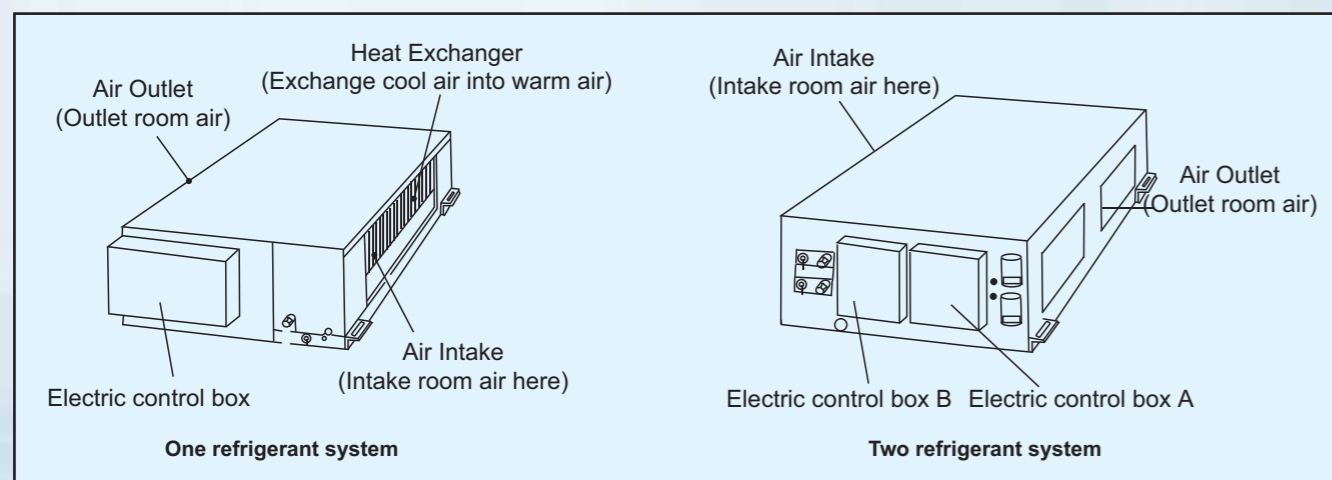

Smart controls

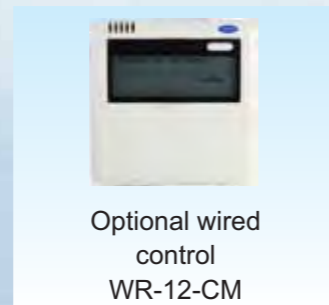

Smart wireless remote controller or optional wired controller with smart, complete control and safety function built in the control systems.

Smart supply airflow

Cooling operation
Adjust the louver horizontally.

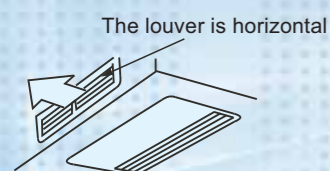

Heating operation
Adjust the louver down(vertically).

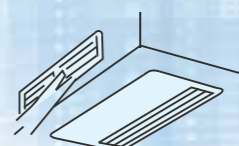

Adjust left and right.
vertical louver

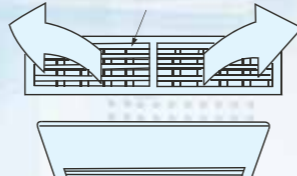

Easy service & maintenance

- Easy removal of air filters for cleaning
- Easy access to indoor unit components
- Remote on / off function and alarm function

42VD H112011010 Series



■ Technical Specifications

Model		42VD028H112011010	42VD032H112011010	42VD036H112011010	42VD048H112011010	42VD054H112011010	42VD055H112011010	
Power supply	V-Ph-Hz	220V-1Ph-50Hz						
Cooling	Capacity	kW	7.1	8	9	11.2	14	16
		Btu/h	24,200	27,300	30,700	38,200	47,800	54,600
	Input power	W	240	240	398	518	648	873
	Rated current	A	1.1	1.1	1.8	2.3	2.7	3.6
Heating	Capacity	kW	8	9	10	12.5	16	17
		Btu/h	27,300	30,700	34,100	42,600	54,600	61,400
	Input power	W	240	240	398	518	648	873
	Rated current	A	1.1	1.1	1.8	2.3	2.7	3.6
Indoor air flow (Hi/Mi/Lo)	cfm	889/823/727	883/822/719	1139/748/889	1246/1147/968	1758/1572/1312	2290/1883/1580	
Indoor external static pressure Std (Min-Max)	Pa	40(30~196)	40(30~196)	40(30~196)	50(30~196)	50(30~196)	50(30~196)	
Indoor sound level (Hi/Mi/Lo)	dB(A)	48/46/44	48/46/44.5	52/49/47	52/49/47	53/50/48	54/52/50	
Indoor unit	Dimension (W×H×D)	mm	952x420x690	952x420x690	952x420x690	952x420x690	1200x400x600	1200x400x600
	Packing (W×H×D)	mm	1090x440x768	1090x440x768	1090x440x768	1090x440x768	1436x450x768	1436x450x768
	Net/Gross weight	Kg	45/50	45/50	46.5/52.4	50.6/56	68/70	70/77.5
Refrigerant type		R410A	R410A	R410A	R410A	R410A	R410A	
Refrigerant control	Type	Electronic expansive valve						
Refrigerant piping	Liquid side/ Gas side	mm	Φ9.53/Φ15.9	Φ9.53/Φ15.9	Φ9.53/Φ15.9	Φ9.52/Φ15.9	Φ9.52/Φ15.9	Φ9.52/Φ15.9
Connection wiring	Signal wiring	Nb×mm ²	3*0.75	3*0.75	3*0.75	3*0.75	3*0.75	3*0.75
Drainage pipe diameter		mm ²	IDΦ25/ODΦ32	IDΦ25/ODΦ32	IDΦ25/ODΦ32	IDΦ25/ODΦ32	IDΦ25/ODΦ32	IDΦ25/ODΦ32
Standard Controller		Wireless remote controller						

■ Technical Specifications

Model		42VD056H112011010	42VD058H112011010	42VD060H112011010	42VD140H112011010	42VD160H112011010	42VD190H112011010	
Power supply	V-Ph-Hz	220V-1Ph-50Hz						
Cooling	Capacity	kW	20	25	28	40	45	56
		Btu/h	68,200	85,300	95,500	1,36,800	1,53,600	1,92,000
	Input power	W	1800	1800	1800	2700	2700	3400
	Rated current	A	6.6	6.6	6.6	12.5	12.5	15.5
Heating	Capacity	kW	22.5	26	31.5	45	50	53
		Btu/h	76,800	88,700	107,500	153,500	170,600	214,960
	Input power	W	1800	1800	1800	2700	2700	3400
	Rated current	A	6.6	6.6	6.6	12.5	12.5	15.5
Indoor air flow (Hi/Mi/Lo)	cfm	2512/2226/1882	2519/2248/1833	2590/2182/1883	4370/3560/2940	4370/3560/2940	5620/4680/3890	
Indoor external static pressure Std (Min-Max)	Pa	140(50~250)	140(50~250)	160(50~250)	200(50~280)	200(50~280)	200(50~280)	
Indoor sound level (Hi/Mi/Lo)	dB(A)	59/55/52	59/55/52	59/55/52	61/59/56	61/59/56	63/60/57	
Indoor unit	Dimension (W×H×D)	mm	1425x500x928	1425x500x928	1425x500x928	1970x668x902.5	1970x668x902.5	1970x668x902.5
	Packing (W×H×D)	mm	1509x550x990	1509x550x990	1509x550x990	2095x800x964	2095x800x964	2095x800x964
	Net/Gross weight	Kg	115/129	115/129	115/129	232/245	232/245	235/250
Refrigerant type		R410A	R410A	R410A	R410A	R410A	R410A	
Refrigerant control	Type	Electronic expansive valve						
Refrigerant piping	Liquid side/Gas side	mm	Φ9.53/Φ15.9x2	Φ9.53/Φ15.9x2	Φ9.53/Φ15.9x2	Φ12.7/Φ28.6x2	Φ12.7/Φ28.6x2	Φ12.7/Φ28.6x2
Connection wiring	Signal wiring	Nb×mm ²	3×0.75	3×0.75	3×0.75	3×0.75	3×0.75	3×0.75
Drainage pipe diameter		mm ²	IDΦ25/ODΦ32	IDΦ25/ODΦ32	IDΦ25/ODΦ32	IDΦ25/ODΦ32	IDΦ25/ODΦ32	IDΦ25/ODΦ32
Standard Controller		Wireless remote controller						

VRF High Wall Indoor Units

42VH VRF High Wall indoor unit is the optimum air conditioning solution for places which require high wall installation, elegant appearance and ultimate comfort combined with efficient, quiet operation, optimum air distribution and efficient Indoor Air Quality (IAQ) and environmentally friendly HFC refrigerant R410A.

VRF Hi Wall



S type panel
2.2 ~ 5.6 kW Cooling
2.4 ~ 6.0 kW Heating
42VH-112000101

Model	006	009	012	018	024
Cooling Capacity	2.2 kW	2.8 kW	3.6 kW	4.5 kW	5.6 kW
Heating Capacity	2.4 kW	3.1 kW	4.0 kW	5.0 kW	6.0 kW

VRF Hi Wall



R type panel
7.1 ~ 9 kW Cooling
8.0 ~ 10 kW Heating
42VH-112000102

Model	028	032	036
Cooling Capacity	7.1 kW	8.0 kW	9.0 kW
Heating Capacity	8.0 kW	9.0 kW	10 kW



VRF High wall (S type panel) 42VH Series

2.2 ~ 5.6 kW Cooling
2.4 ~ 6.0 kW Heating



- Auto Restart
- Auto Addressing
- Cleanable Panel
- Anti-Cold Air Function
- LED Display
- Wireless Controller
- Wired Controller
- Follow Me

Smart LED display

The front panel and display panel have different colors for choose: white and brown for big panel, blue and brown for small panel, and the other colors can be customized according to the customers' demands.

Easy and flexible installation

- Compact dimensions and footprint. Flexible multi outlet location of refrigerant piping lines : left / right / back satisfy the need of different rooms.
- Built-in EXV the indoor unit, compact size, Longer the connection pipe, Gas pipe: 468mm/Liquid pipe: 550mm, more flexible for the installation
- Adopts new type fixing plate, easy for installation and stable.

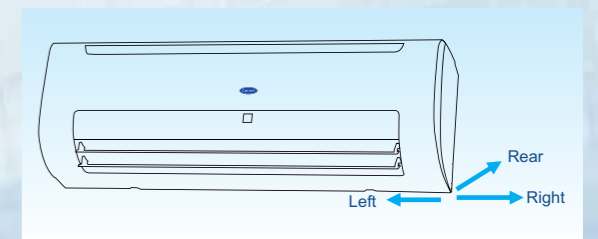

Smart auto swing louver

Smart supply airflow for comfort cool and heat : motorized horizontal air flap with angles as per selected mode for optimal air distribution of supply air temperature and velocity inside air conditioned space.

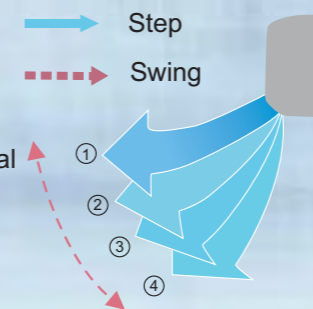

Easy service and maintenance

Easy service and maintenance has been realized as the front panel can removed for easy access.



Part names

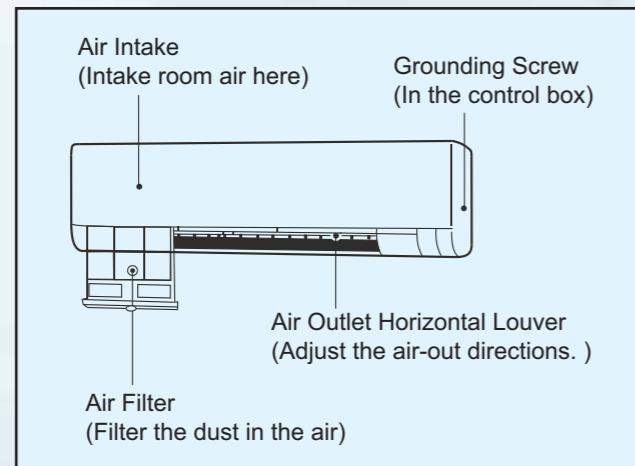

42VH 112000101 Series (S Type Panel)



■ Technical Specifications

Model (Standard)			42VH006H112000101	42VH009H112000101	42VH012H112000101
Power supply		V- Ph-Hz	220~240V-1Ph-50Hz		
Cooling	Capacity	kW	2.2	2.8	3.6
		Btu/h	7,500	9,500	12,200
	Input power	W	31	31	31
Heating	Capacity	kW	2.4	3.1	4
		Btu/h	8,200	10,500	13,600
	Input power	W	31	31	31
Indoor air flow (H/M/L)		cfm	309/283/253	309/283/253	309/283/253
Indoor sound level (H/M/L)		dB(A)	35/32/29	35/32/29	35/32/29
Indoor unit	Dimension (WxHxD)	mm	915 x 290 x 230	915 x 290 x 230	915 x 290 x 230
	Packing (WxHxD)	mm	1020 x 390 x 315	1020 x 390 x 315	1020 x 390 x 315
	Net/Gross weight	kg	13.3/16.5 13.3/16.8 (With Heater)	13.3/16.5 13.3/16.8 (With Heater)	13/16.5 13.3/16.8 (With Heater)
Refrigerant type			R410A	R410A	R410A
Refrigerant control		Type	Inside Electronic expansive valve		
Refrigerant piping	Liquid side/Gas side	mm	6.35/12.7	6.35/12.7	6.35/12.7
Connecting wiring	Signal wiring	Nb×mm ²	3x0.75	3x0.75	3x0.75
Drainage water pipe diameter		mm	ODΦ16.5	ODΦ16.5	ODΦ16.5
Standard Controller			Wireless remote controller		

Smart controls

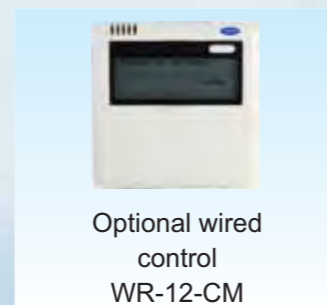

Smart wireless remote controller or optional wired controller with smart, complete control and safety function built in the control systems.

Smart supply airflow

Auto-swing

Press SWING button, the louver will swing up and down automatically.

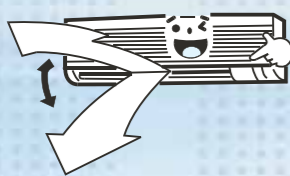

When cooling

Adjust the louver horizontally

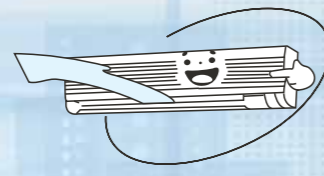

When heating

Adjust the louver downwards (vertically).

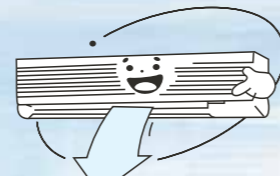

Easy service & maintenance

- Easy removal of air filters for cleaning

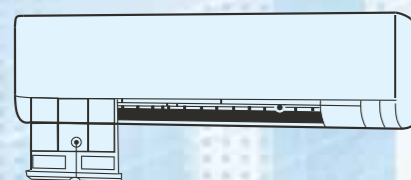

Air Filter
(Filter the dust in the air)

- Easy access to indoor unit components
- Remote on / off function and alarm function

42VH 112000101 Series (S Type Panel)



Technical Specifications

Model (Standard)			42VH018H112000101	42VH024H112000101
Power supply		V- Ph-Hz	220~240V-1Ph-50Hz	
Cooling	Capacity	kW	4.5	5.6
		Btu/h	15,300	19,100
	Input power	W	44	44
Heating	Capacity	kW	5	6
		Btu/h	17,000	20,400
	Input power	W	44	44
Indoor air flow (H/M/L)		cfm	506/444/371	544/506/444
Indoor sound level (H/M/L)		dB(A)	40/38/34	40/38/34
Indoor unit	Dimension (WxHxD)	mm	1072 x 315 x 230	1072 x 315 x 230
	Packing (WxHxD)	mm	1180 x 415 x 315	1180 x 415 x 315
	Net/Gross weight	kg	15.1/18.8 15.5/19.2(With Heater)	15.1/18.8 15.5/19.2(With Heater)
Refrigerant type			R410A	R410A
Refrigerant control		Type	Inside Electronic expansive valve	
Refrigerant piping	Liquid side / Gas side	mm	6.35/12.7	9.53/15.9
Connecting wiring	Signal wiring	Nb×mm ²	3×0.75	3×0.75
Drainage water pipe diameter		mm	ODΦ16.5	ODΦ16.5
Standard Controller			Wireless remote controller	

VRF High wall (R type panel) 42VH Series 7.1 ~ 9 kW Cooling 8.0 ~ 10 kW Heating



- Auto Restart
- Auto Addressing
- Cleanable Panel
- Anti-Cold Air Function
- LED Display
- Wireless Controller
- Wired Controller
- Follow Me

Smart LED display

The front panel and display panel have different colors for choose: white and brown for big panel, blue and brown for small panel, and the other colors can be customized according to the customers' demands.

Easy and flexible installation

- Compact dimensions and footprint. Flexible multi outlet location of refrigerant piping lines : left / right / back satisfy the need of different rooms.
- Built-in EXV the indoor unit, compact size, Longer the connection pipe, Gas pipe: 468mm/Liquid pipe: 550mm, more flexible for the installation
- Adopts new type fixing plate, easy for installation and stable.

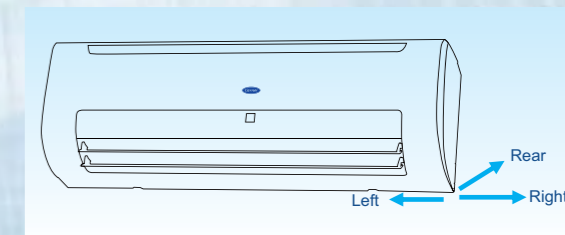

Smart auto swing louver

Smart supply airflow for comfort cool and heat : motorized horizontal air flap with angles as per selected mode for optimal air distribution of supply air temperature and velocity inside air conditioned space.

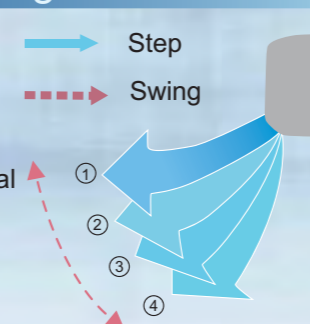

Easy service and maintenance

Easy service and maintenance has been realized as the front panel can removed for easy access.



42VH 112000102 Series (R Type Panel)



Part names

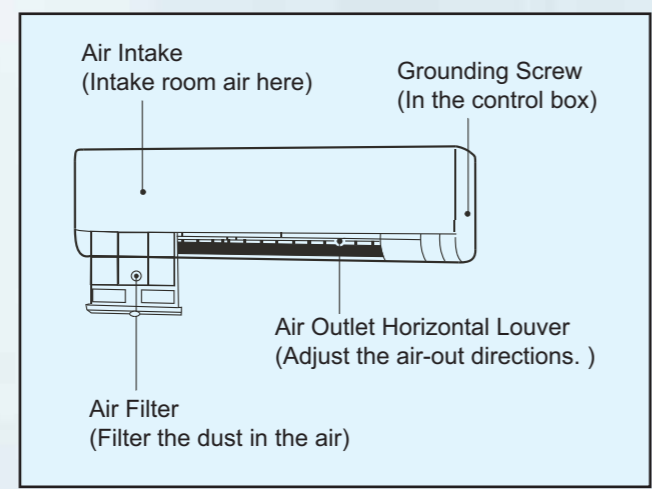

Smart controls



Smart wireless remote controller or optional wired controller with smart, complete control and safety function built in the control systems.

Smart supply airflow

Auto-swing

Press SWING button, the louver will swing up and down automatically.



When cooling

Adjust the louver horizontally

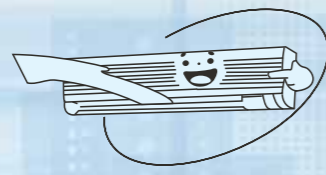

When heating

Adjust the louver downwards (vertically).

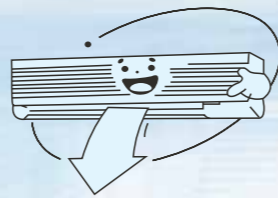

Easy service & maintenance

- Easy removal of air filters for cleaning

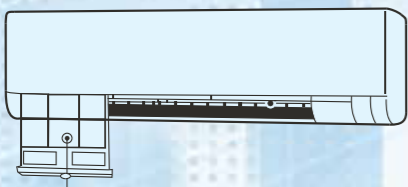

Air Filter
(Filter the dust in the air)

- Easy access to indoor unit components
- Remote on / off function and alarm function

Model (Standard)			42VH028H112000102	42VH032H112000102	42VH036H112000102
Power supply		V- Ph-Hz	220~240V-1Ph-50Hz		
Cooling	Capacity	kW	7.1	8	9
		Btu/h	24200	27300	30700
	Input power	W	75	86	86
	Rated current	A	0.33	0.39	0.39
Heating	Capacity	kW	8	9	10
		Btu/h	27300	30700	34100
	Input power	W	75	86	86
	Rated current	A	0.33	0.39	0.39
Sound level (H/M/L)		dB (A)	47/43/42	48/43/38	49/43/38
Indoor air flow (H/M/L)		cfm	701/518/401	776/494/377	776/494/377
Indoor unit	Dimension (WxHxD)	mm	1250x245x325	1250x245x325	1250x245x325
	Packing (WxHxD)	mm	1345x335x430	345x335x430	345x335x430
	Net/Gross weight	kg	19.9/25	19.9/25	19.9/25
Refrigerant type			R410A	R410A	R410A
Refrigerant control		Type	Electronic expansive valve		
Refrigerant piping	Liquid side/Gas side	mm	Φ9.53/Φ15.9	Φ9.53/Φ15.9	Φ9.53/Φ15.9
Connecting wiring	Signal wiring	Nb×mm ²	3×0.75	3×0.75	3×0.75
Drainage water pipe diameter		mm	ODΦ16.5	ODΦ16.5	ODΦ16.5
Standard Controller			Wireless remote controller		

VRF FLOOR / UNDER CEILING INDOOR UNITS

42VF VRF Floor / Under Ceiling indoor unit is the optimum air conditioning solution for places which require floor or wall or under-ceiling installations, elegant appearance and ultimate comfort combined with efficient and quiet operation, optimum air distribution, and efficient Indoor Air Quality (IAQ).

42VF is the very latest in slim line technology and art of air conditioning design and environmentally friendly HFC refrigerant R410A.

42VF compact dimensions make possible a wide range of applications, even under a window sill.

All units can be mounted on the floor, on the wall or under the ceiling.

42VF sizes have been designed for fitting luxury houses and prestigious offices.

VRF Floor / Under Ceiling 42VF Series

3.6 ~ 14.0 kW Cooling

4.0 ~ 15.5 kW Heating



- Auto Restart
- Auto Addressing
- Built-in Drain Pump
- Wireless Controller
- Wired Controller
- Fresh Air
- Cleanable Panel
- Anti-Cold Air Function
- LED Display
- Follow Me

Smart LED display

The front panel and display panel have different colors for choose: white and brown for big panel, blue and brown for small panel, and the other colors can be customized according to the customers' demands.

Easy and flexible installation

- The ceiling type can be easily installed into a corner of the ceiling even if the ceiling is very narrow
- It is especially useful when installation of an air conditioner in the center of the ceiling is impossible due to a structure such as one lighting



The unit can be installed either horizontally on the ceiling or vertically against the wall.

Low noise, creates quiet and comfortable environment.

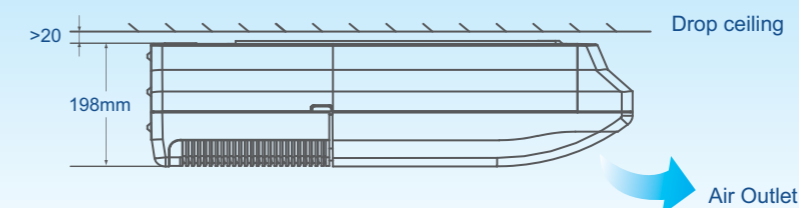

- Slim and sleek design starting at just 30kg in weight means quick, easy & neat installation.
- Low noise operation, lowest to 36 dB(A)

Auto swing and wide angle air flow

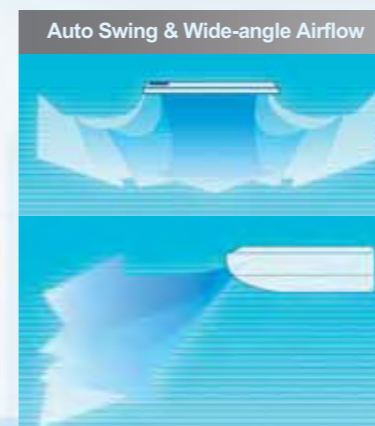

1. The unit has auto horizontal swing and auto vertical swing function, which supplies more even and comfortable airflow.
2. Three air flow speed: high/middle/low, double air guides.
3. Adoption of the electronic expansion valve, ensure precise flow control, as well lower modulation noise when EXV operating.
4. Smoother airflow with less turbulence. Owing to the multiple-blade fan and the air guide design, the airflow is getting smoother and more comfortable.

VRF Floor / Under Ceiling



3.6 ~ 14.0 kW Cooling
4.0 ~ 15.5 kW Heating

42VF-H112000010

Model	012	018	024	028
Cooling Capacity	3.6 kW	4.5 kW	5.6 kW	7.1 kW
Heating Capacity	4.0 kW	5.0 kW	6.3 kW	8.0 kW

Model	032	036	048	054
Cooling Capacity	8.0 kW	9.0 kW	11.2 kW	14.0 kW
Heating Capacity	9.0 kW	10.0 kW	12.5 kW	15.5 kW



Part names

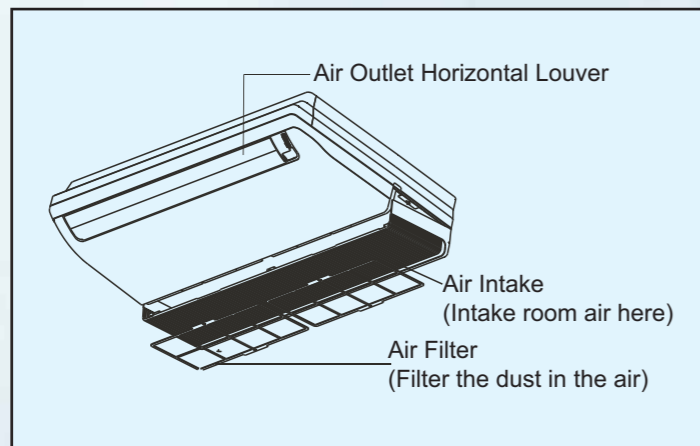

Smart controls

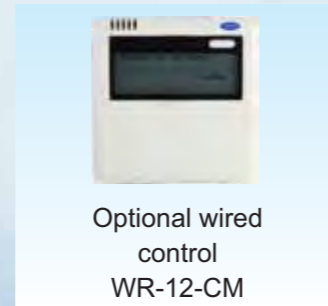

Smart wireless remote controller or optional wired controller with smart, complete control and safety function built in the control systems.

Smart supply airflow

Auto-swing

Press SWING button, the louver will swing up and down (left and right) automatically.

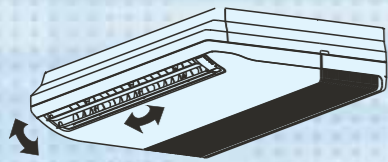

When cooling

Adjust the louver horizontally.

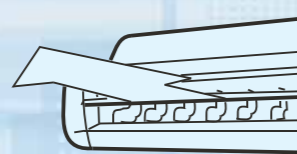

When heating

Adjust the louver downwards (vertically).

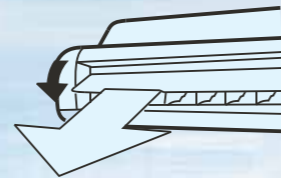

Easy service & maintenance

- Easy removal of air filters for cleaning

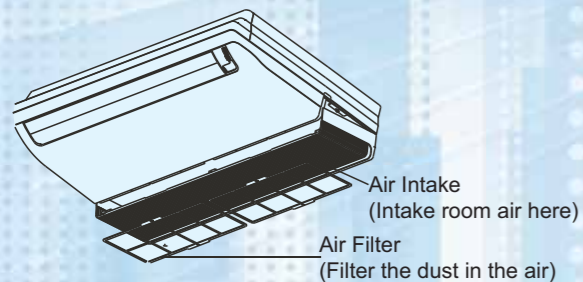

- Easy access to indoor unit components
- Remote on / off function and alarm function

42VF Series



Technical Specifications

Model			42VF012H112000010	42VF018H112000010	42VF024H112000010	42VF028H112000010
Power supply		V-ph-Hz	220-240V-1Ph-50Hz			
Cooling	Capacity	kW	3.6	4.5	5.6	7.1
		Btu/h	12,200	15,300	19,100	24,200
	Input power	W	34	125	125	125
Heating	Capacity	kW	4	5	6	8
		Btu/h	13,600	17,000	20,500	27,300
	Input power	W	34	125	125	125
Indoor air flow (Hi/Mi/Lo)		cfm	383/335/294	471/353/294	471/353/294	471/353/294
Sound level (H/M/L)		dB(A)	40/38/36	43/41/38	43/41/38	43/41/38
Indoor unit	Dimension (WxHxD)	mm	990x660x206	990x660x206	990x660x206	990x660x206
	Packing (WxHxD)	mm	1090x745x297	1090x745x297	1090x745x297	1090x745x297
	Net/Gross weight	kg	28/34	29/35	29/35	29/35
Refrigerant Type			R410A	R410A	R410A	R410A
Refrigerant piping	Liquid side/Gas side	mm	Φ6.35/Φ12.7	Φ6.35/Φ12.7	Φ9.53/Φ16	Φ9.53/Φ16
Connection wiring	Signal wiring	mm ²	3×0.75			
Drainage water pipe diameter		mm	ODΦ16			
Standard Controller			Wireless remote controller			

42 VF Series



■ Technical Specifications

Model		42VF032H112000010	42VF036H112000010	42VF048H112000010	42VF054H112000010	
Power supply		V-ph-Hz	220~240V-1Ph-50Hz			
Cooling	Capacity	kW	8	9	11.2	14
		Btu/h	27,300	30,700	38,200	47,800
	Input power	W	143	143	182	182
Heating	Capacity	kW	9	10	12.5	15.5
		Btu/h	30700	34100	42600	52900
	Input power	W	143	143	182	182
Indoor air flow (Hi/Mi/Lo)		cfm	706/530/412	706/530/412	1165/1095/1018	1165/1095/1018
Sound level (H/M/L)		dB(A)	45/43/40	45/43/40	47/45/42	47/45/42
Indoor unit	Dimension (WxHxD)	mm	1280x660x206	1280x660x206	1670x680x244	1670x680x244
	Packing (WxHxD)	mm	1380x745x297	1380x745x297	1765x760x330	1765x760x330
	Net/Gross weight	kg	34/41	34/41	49/58	49/58
Refrigerant type			R410A	R410A	R410A	R410A
Refrigerant piping	Liquid side/Gas side	mm	Φ9.53/Φ16	Φ9.53/Φ16	Φ9.53/Φ16	Φ9.53/Φ16
Connection wiring	Signal wiring	mm ²	3×0.75			
Drainage water pipe diameter		mm	ODΦ16			
Standard Controller			Wireless remote controller			

VRF Console

VRF Console



2.2 ~ 4.5 kW Cooling
2.6 ~ 5.0 kW Heating

42VC-H112000010

Model	006	009	012	018
Cooling Capacity	2.2 kW	2.8 kW	3.6 kW	4.5 kW
Heating Capacity	2.6 kW	3.2 kW	4.0 kW	5.0 kW



VRF Console 42VC Series

2.2 ~ 4.5 kW Cooling

2.6 ~ 5.0 kW Heating



- Auto Restart
- Auto Addressing
- Cleanable Panel
- Anti-Cold Air Function
- LED Display
- Wireless Controller
- Wired Controller
- Follow Me

Compact unit body, space saving, nice-looking appearance

- This unit body is very thin and harmonious with room. It is elegant and space saving.
- The EXV is fixed inside of the indoor unit, Compact unit body.



Easy and flexible installation

- Can be installed floor or low wall.
- As a floor standing type, it can be semi or fully cessed without loss of capacity.

High Comfort

- Flexible air blow: vertical auto swing and wide angle louvers ensure that warm air reaches the furthest corners of the room and increase the air flow coverage
- Indoor unit adopts DC motor which has five level fan speed meet different requirements.
- Adoption of the Fujikoki brand mechanical expansion valve which has 2000 stages element positioning, ensure precise flow control, as well lower modulation noise when EXV operating.

Powerful mode can be selected for rapid cooling or heating.

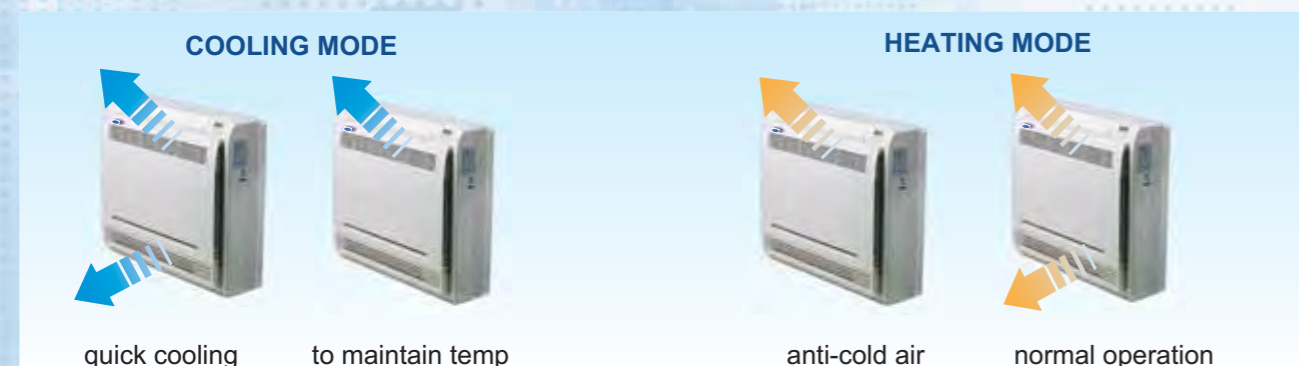

Part names

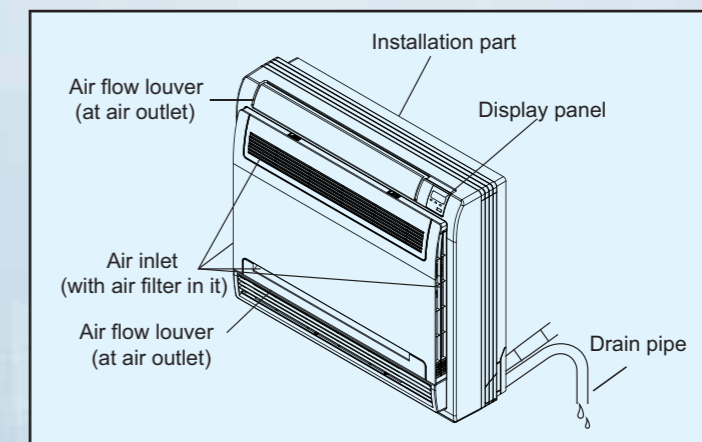

Smart controls



Standard wireless remote control WL-12-CM



Optional wired control WR-12-CM

Smart wireless remote controller or optional wired controller with smart, complete control and safety function built in the control systems.

Smart supply airflow

Auto-swing

Press SWING button, the louver will swing up and down (left and right) automatically.

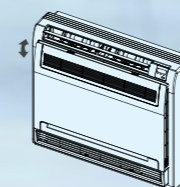

When cooling

Adjust the louver horizontally.



When heating

Adjust the louver downwards (vertically).



Easy service & maintenance

- Easy removal of air filters for cleaning

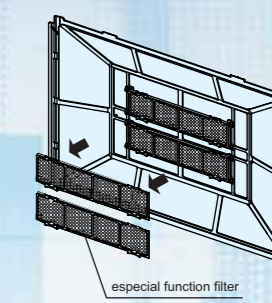
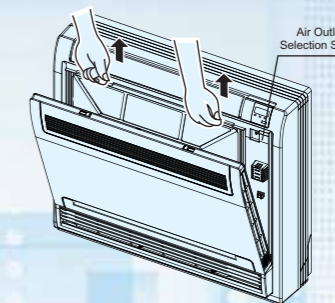
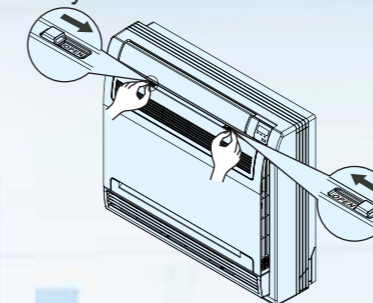

- Easy access to indoor unit components
- Remote on / off function and alarm function

High efficiency filter

- Built in Formaldehyde nemesis filter
- Active-carbon and biological anti-virus filter is optional.

Two air outlet, Four air inlet

Air inlet from 4 directions, there are 2 optional air-outlet ways, Both up and Down air-outlet or up air-outlet only.



42VC Series



■ Technical Specifications

Model		42VC006H112000010	42VC009H112000010	42VC012H112000010	42VC018H112000010	
Power supply		V- Ph-Hz 220~240V-1Ph-50Hz				
Cooling	Capacity	kW	2.2	2.8	3.6	4.5
		Btu/h	7,500	9,500	12,200	15,300
	Input power	W	20	24	44	44
Heating	Capacity	kW	2.6	3.2	4	5
		Btu/h	8,900	10,900	13,600	17,000
	Input power	W	20	24	44	44
Indoor air flow (H/M/L)		cfm	253/203/135	300/253/135	300/253/135	388/300/235
Indoor sound level (Hi/Mid/Lo)		dB(A)	38/32/26	39/33/27	39/33/27	42/39/36
Indoor unit	Dimension (WxHxD)	mm	700*600*210			
	Packing (WxHxD)	mm	810*710*305			
	Net/Gross weight	kg	14/19	15/20	15/20	15/20
Refrigerant type		R410A				
Refrigerant control		Type	EXV			
Refrigerant piping	Liquid side/Gas side	mm	Φ6.35/Φ12.7			
Connecting wiring	Signal wiring	mm ²	3×0.75			
Drainage water pipe diameter		mm	ODΦ16			
Standard Controller		Wireless remote controller				

Quiet Design

Five speeds indoor unit, Low noise and Energy saving.



Low noise operation, lowest to 26dB(A)

VRF FLOOR STANDING

VRF Floor Standing



Exposed
42VS-H112002010



Concealed
42VS-H112003010

2.2 ~ 8.0 kW Cooling
2.4 ~ 9.0 kW Heating

Model	006	009	012	018
Cooling Capacity	2.2 kW	2.8 kW	3.6 kW	4.5 kW
Heating Capacity	2.4 kW	3.2 kW	4.0 kW	5.0 kW

Model	024	028	032
Cooling Capacity	5.6 kW	7.1 kW	8.0 kW
Heating Capacity	6.3 kW	8.0 kW	9.0 kW

VRF Floor Standing 42 VS Series (Exposed)

2.2 ~ 8 kW Cooling
2.4 ~ 9 kW Heating

- Auto Restart
- Auto Addressing
- Follow Me
- Cleanable Panel
- Anti-Cold Air Function
- LED Display

Exposed floor standing with front air intake
42VS-H112002010



Concealed floor standing
42VS-H112003010

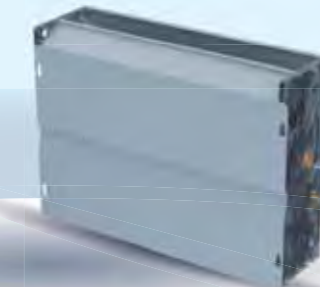

Easy and flexible installation

Floor standing types can be hung on the wall or installed on the floor. The former can make cleaning and maintenance much more easily. Running the piping from the back allows the unit to be hung on walls. Cleaning under the unit, where dust tends to accumulate, is considerably easier.

Easy service and maintenance

Filters are equipped as standard accessory, and it can be removed and cleaned easily due to sophisticated design as well as the removable blades.

Streamlined appearance makes it much more harmonious with the decoration. All metal parts are made of commercial grade galvanized steel, providing maximum protection against corrosion.

So compact that it fits into even a tiny space

The body is concealed in the skirting-wall to pursue harmony with the interior. With 212mm depth of body dimension, it can be installed in the perimeter zone.

Low noise level due to special installation method for not exposed in the room space.

Part names

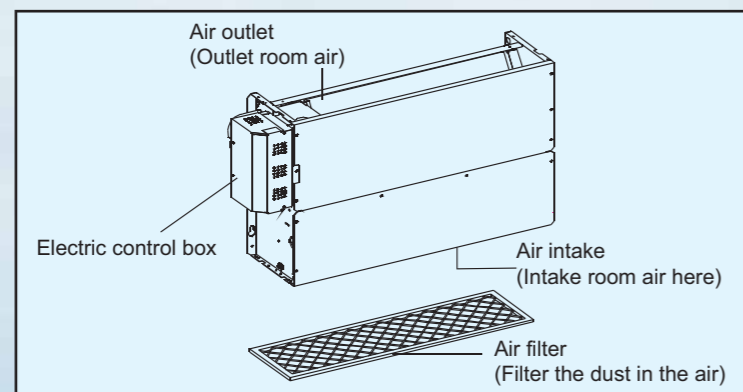
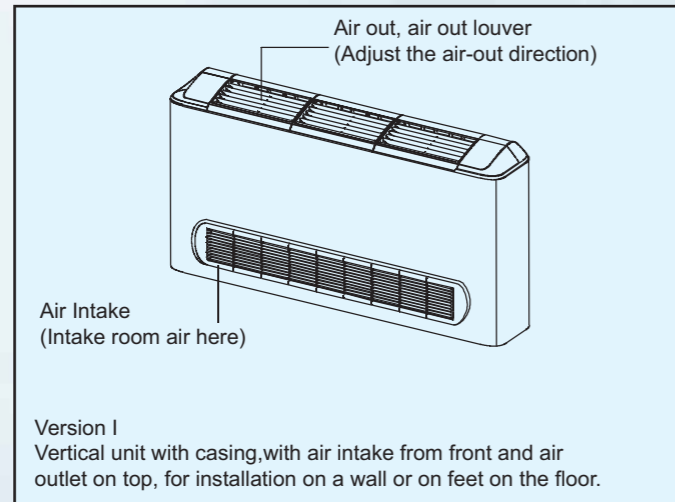

42VS H112002010 Series (Exposed)



42VS-H112002010
Exposed floor standing
with front air intake

■ Technical Specifications

Model (Front air intake)		42VS006H112002010	42VS009H112002010	42VS012H112002010	42VS018H112002010	
Power supply		V- Ph-Hz	220~240V-1Ph-50Hz			
Cooling	Capacity	kW	2.2	2.8	3.6	4.5
		Btu/h	7,500	9,500	12,200	15,300
Cooling	Input power	W	40	40	49	49
Heating	Capacity	kW	2.4	3.2	4	5
		Btu/h	8,200	10,900	13,600	17,000
Heating	Input power	W	40	40	49	49
Indoor air flow (H/M/L)		cfm	312/268/235	335/285/248	367/307/221	388/319/259
Indoor sound level (Hi/Mid/Lo)		dB(A)	36/33/29	36/33/29	37/34/30	37/34/30
Indoor unit	Dimension (W×H×D)	mm	1000x220x625	1000x220x625	1200x220x625	1200x220x625
	Packing (W×H×D)	mm	1090x685x313	1090x685x313	1290x685x313	1290x685x313
	Net/Gross weight	kg	30/35	30/35	37/43	37/43
Refrigerant type			R410A			
Refrigerant control	Type		Electronic expansion valve			
Refrigerant piping	Liquid side/Gas side	mm	Φ6.35/Φ12.7			
Connecting wiring	Signal wiring	mm ²	3×0.75			
Drainage water pipe diameter		mm	ODΦ16			
Standard Controller			Wireless remote controller			

Smart controls

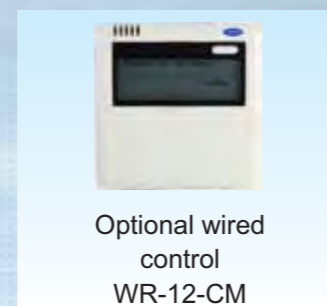

Smart wireless remote controller or optional wired controller with smart, complete control and safety function built in the control systems.

Smart supply airflow

Auto-swing

Press SWING button, the louver will swing up and down (left and right) automatically.

When cooling

Adjust the louver horizontally.

When heating

Adjust the louver downwards (vertically).

Easy service & maintenance

- Easy removal of air filters for cleaning
- Easy access to indoor unit components
- Remote on / off function and alarm function

42VS H112002010 Series (Exposed)



42VS-H112002010
Exposed version with air
intake from front

■ Technical Specifications

Model (Front air intake)			42VS024H112002010	42VS028H112002010	42VS024H112002010
Power supply		V- Ph-Hz	220~240V-1Ph-50Hz		
Cooling	Capacity	kW	5.6	7.1	8
		Btu/h	19,100	24,200	27,300
Cooling	Input power	W	95	139	139
Heating	Capacity	kW	6.3	8	9
		Btu/h	21,500	27,300	30,700
Heating	Input power	W	95	139	139
Indoor air flow (H/M/L)		cfm	677/571/489	812/647/512	784/713/602
Indoor sound level (Hi/Mid/Lo)		dB(A)	41/35/31	44/39/33	44/39/33
Indoor unit	Dimension (W×H×D)	mm	1500x220x625	1500x220x625	1500x220x625
	Packing (W×H×D)	mm	1500x685x313	1500x685x313	1500x685x313
	Net/Gross weight	kg	44/50	44/50	44/50
Refrigerant type		R410A			
Refrigerant control		Type	Electronic expansion valve		
Refrigerant piping	Liquid side/Gas side	mm	Φ6.35/Φ12.7		
Connecting wiring	Signal wiring	mm ²	3×0.75		
Drainage water pipe diameter		mm	ODΦ 16		
Standard Controller		Wireless remote controller			

42VS H112003010 Series (Concealed)



42VS-H112003010

■ Technical Specifications

Model			42VS006H112003010	42VS009H112003010	42VS012H112003010	42VS018H112003010
Power supply		V- Ph-Hz	220~240V-1Ph-50Hz			
Cooling	Capacity	kW	2.2	2.8	3.6	4.5
		Btu/h	7,500	9,500	12,200	15,300
Cooling	Input power	W	40	45	49	50
Heating	Capacity	kW	2.4	3.2	4	5
		Btu/h	8,200	10,900	13,600	17,000
Heating	Input power	W	40	45	49	50
Indoor air flow (H/M/L)		cfm	312/268/235	335/285/248	367/307/220	388/319/259
Indoor external static pressure (Hi)		Pa	0/0/10	0/0/10	0/0/10	0/0/10
Indoor sound level (Sound pressure)(Hi/Mi/Lo)		dB(A)	36/33/29	36/33/29	37/34/30	37/34/30
Indoor unit	Dimension (WxHxD)	mm	840/212/545	840/212/545	1036x212x545	1036x212x545
	Packing (WxHxD)	mm	925x640x305	925x640x305	1125x640x305	1125x640x305
	Net/Gross weight	kg	22/25.5	22/25.5	29.5/34	29.5/34
Refrigerant type		R410A				
Refrigerant control		Type	Electronic expansion valve			
Refrigerant piping	Liquid side/Gas side	mm	Φ6.35/Φ12.7	Φ6.35/Φ12.7	Φ6.35/Φ12.7	Φ6.35/Φ12.7
Connecting wiring	Signal wiring	mm ²	3×0.75			
Drainage water pipe diameter		mm	ODΦ 16			
Standard Controller		Wireless remote controller				

42VS H112003010 Series (Concealed)



42VS-H112003010

■ Technical Specifications

Model		42VS024H112003010	42VS028H112003010	42VS032H112003010	
Power supply		V- Ph-Hz	220~240V-1Ph-50Hz		
Cooling	Capacity	kW	5.6	7.1	8
		Btw/h	19,100	24,200	27,300
	Input power	W	95	139	139
Heating	Capacity	kW	6.3	8	9
		Btw/h	21,500	27,300	30,700
	Input power	W	95	139	139
Indoor air flow (H/M/L)		cfm	676/570/488	811/647/512	783/713/602
Indoor external static pressure (Hi)		Pa	0/0/10	0/0/10	0/0/10
Indoor sound level (Sound pressure)(Hi/Mi/Lo)		dB(A)	41/35/31	44/39/33	44/39/33
Indoor unit	Dimension (WxHxD)	mm	1336x212x545	1336x212x545	1336x212x545
	Packing (WxHxD)	mm	1425x640x305	1425x640x305	1425x640x305
	Net/Gross weight	kg	36/40	36/40	36/40
Refrigerant type		R410A			
Refrigerant control		Type	Electronic expansion valve		
Refrigerant piping	Liquid side/Gas side	mm	Φ9.52/Φ16		
Connecting wiring	Signal wiring	mm ²	3×0.75		
Drainage water pipe diameter		mm	ODΦ16		
Standard Controller		Wireless remote controller			

VRF FRESH AIR PROCESSING UNIT

VRF Fresh Air Processing Unit



12.5 ~ 28 kW Cooling
10.5 ~ 22 kW Heating

42VD-H112211010

Model	050	054	056	058	060
Cooling Capacity	12.5 kW	14 kW	20.0 kW	25.0 kW	28.0 kW
Heating Capacity	10.5 kW	12 kW	18.0 kW	20.0 kW	22.0 kW



VRF Fresh Air Processing unit 42VD Series

12.5 ~ 28 kW Cooling
10.5 ~ 22 kW Heating



Creating comfortable and healthier climate

Fresh air are introduced into the environment, improved air quality Create comfortable and healthier climate

100% Fresh air processing unit

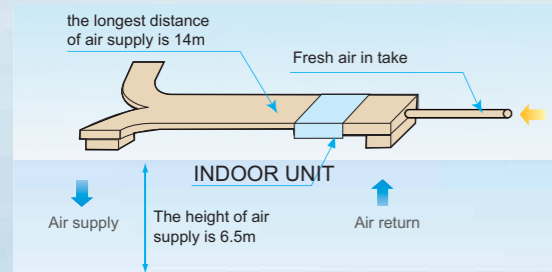

Both fresh air filtration and heating/cooling can be achieved in a single system. Indoor units and fresh air processing unit can be connected to the same refrigerant system, resulting in enhanced design flexibility and a significant reduction in total system costs.

High external static pressure

External static pressure can be up to 220Pa(052~054 models) and 260Pa(056~060 models) for more flexible duct applications. The maximal distance of air supply is about 14m and the maximum height of air supply is about 6.5m.

Innovative air supply technology for excellent room temperature control.

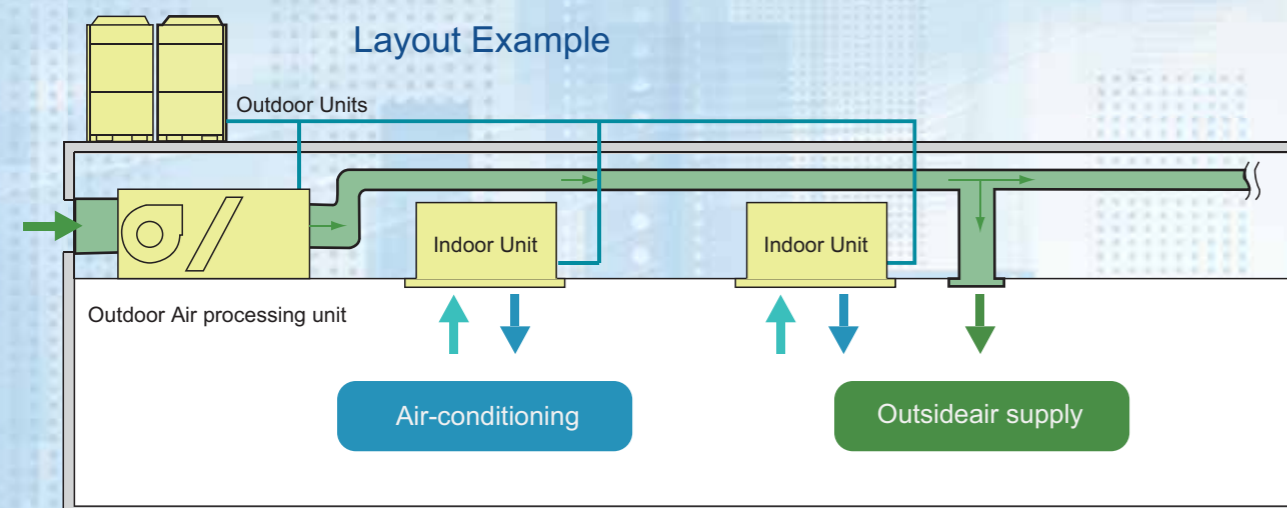

42VD H112211010 Series

■ Technical Specifications

Model		42VD050H112211010	42VD054H112211010	42VD056H112211010	42VD058H112211010	42VD060H112211010	
Power supply		V-Ph-Hz	220-240V-1Ph-50Hz				
Cooling(*1)	Capacity	kW	12.5	14	20	25	28
		Btu/h	42,600	47,800	68,200	85,300	95,500
	Input power	W	568	568	1,300	1,350	1,350
	Rated current	A	2.4	2.4	5.3	5.6	5.6
Heating(*2)	Capacity	kW	10.5	16	18	20	22
		Btu/h	35,800	54,600	61,400	68,200	75,000
	Input power	W	568	568	1,300	1,350	1,350
	Rated current	A	2.4	2.4	5.3	5.6	5.6
Indoor air flow (Hi/Mid/Lo)		cfm	1000/795/618	1000/795/618	1854/1560/1354	1942/1677/1471	1942/1677/1471
Indoor external static pressure Std (Min-Max)		Pa	50(30~220)	50(30~220)	140(50~260)	140(50~260)	140(50~260)
Indoor sound level(*3) (Sound pressure)(Hi/Mid/Lo)		dB(A)	54/52/50	54/52/50	54/53/51	55/54/52	55/54/52
Indoor unit	Dimension (W×H×D)	mm	1368x420x691	1368x420x691	1443x470x810	1443x470x810	1443x470x810
	Packing (W×H×D)	mm	1436x450x768	1436x450x768	1509x550x990	1509x550x990	1509x550x990
	Net/Gross weight	Kg	69.5/76	69.5/76	115/125	115/125	115/125
Refrigerant type			R410A	R410A	R410A	R410A	R410A
Refrigerant control		Type	Electronic expansion valve				
Refrigerant piping	Liquid side/Gas side	mm	Φ9.52/Φ15.9	Φ9.52/Φ15.9	Φ9.52/Φ15.9	Φ9.52/Φ15.9	Φ9.52/Φ15.9
Connection wiring	Signal wiring	Nb×mm ²	3*0.75	3*0.75	3x1.0	3x1.0	3x1.0
Drainage pipe diameter		mm ²	Φ25	Φ25	Φ32	Φ32	Φ32
Standard Controller			Wireless remote controller				

Notes:

- Nominal cooling capacities are based on the following conditions: outdoor air temp.: 33°C DB, 24°C WB, equivalent ref. piping: 8m (horizontal)
- Nominal heating capacities are based on the following conditions: outdoor air temp.: 0°CDB, -1°CWB, equivalent ref. Piping: 8m (horizontal)
- Sound level is measured 1.4m from the air out-let.

- * external static pressure are based on high speed indoor air flow.
- * Specifications are subject to change without prior notice for product improvement.

Connection Conditions:

The following restrictions must be observed in order to maintain the indoor units connected to the same system.

- * When outdoor-air processing units are connected, the total connection capacity must be within 50% to 100% of that of the outdoor units.
- * When outdoor-air processing units and standard indoor units are connected, the total connection capacity of the outdoor-air processing units must not exceed 30% of that of the outdoor units.
- * Outdoor-air processing units can be used without indoor units.

VRF AHU KIT AHUKZ SERIES



Technical Specifications

Model		AHUKZ-01B	AHUKZ-02B	AHUKZ-03B
Power supply		220~240V-1Ph-50Hz		
Indoor unit capacity	kW	9~20	20~360	360~560
IP-class		IPX0	IPX0	IPX0
Piping size (in/out)	mm	Φ8/Φ8	Φ12.7/Φ12.7	Φ15.9/Φ15.9
Dimension	mm	375×350×150		
Packing dimension	mm	490×240×420		

Capacity	AHUKZ-01B				AHUKZ-02B				AHUKZ-03B			
HP	3.2	4	5	6	8	10	12	14	16	18	20	

AHU Kit should be installed vertically as shown below:

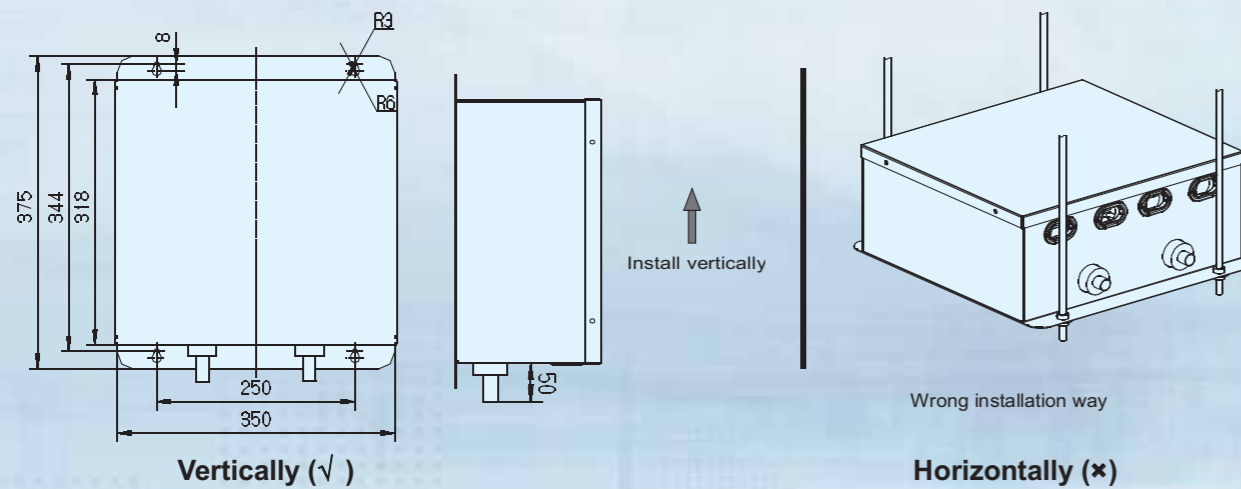

Wiring diagram between indoor and outdoor units

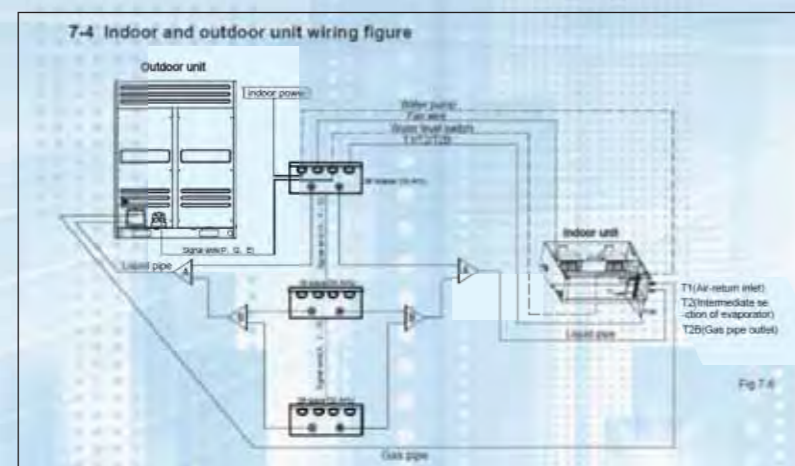

Features

- Built in expansion valve
- Maximum 4 AHU control box can be combined (maximum capacity 80HP)
- Self diagnosis function

CONTROL DEVICES

Type			
Individual Controller	Remote controller	WL-12-CM	
	Wired controller	WR-12-CM	WR-29-CM
Centralized Controller		CRF-10-CM	WCRF-10-CM
		CRC-10-CM	CRM-30-CM-B
	BMS Gateway	BACNET Gateway	MODBUS Gateway
		LONWORK Gateway	
Network Control Software & Hardware			
		Used for network control and power fee calculation.	
Accessories		Hotel card	Infra-red
		NIM	ODU alarm module
	Data converter	digital power meter	

CONTROL SYSTEMS

Building Management System

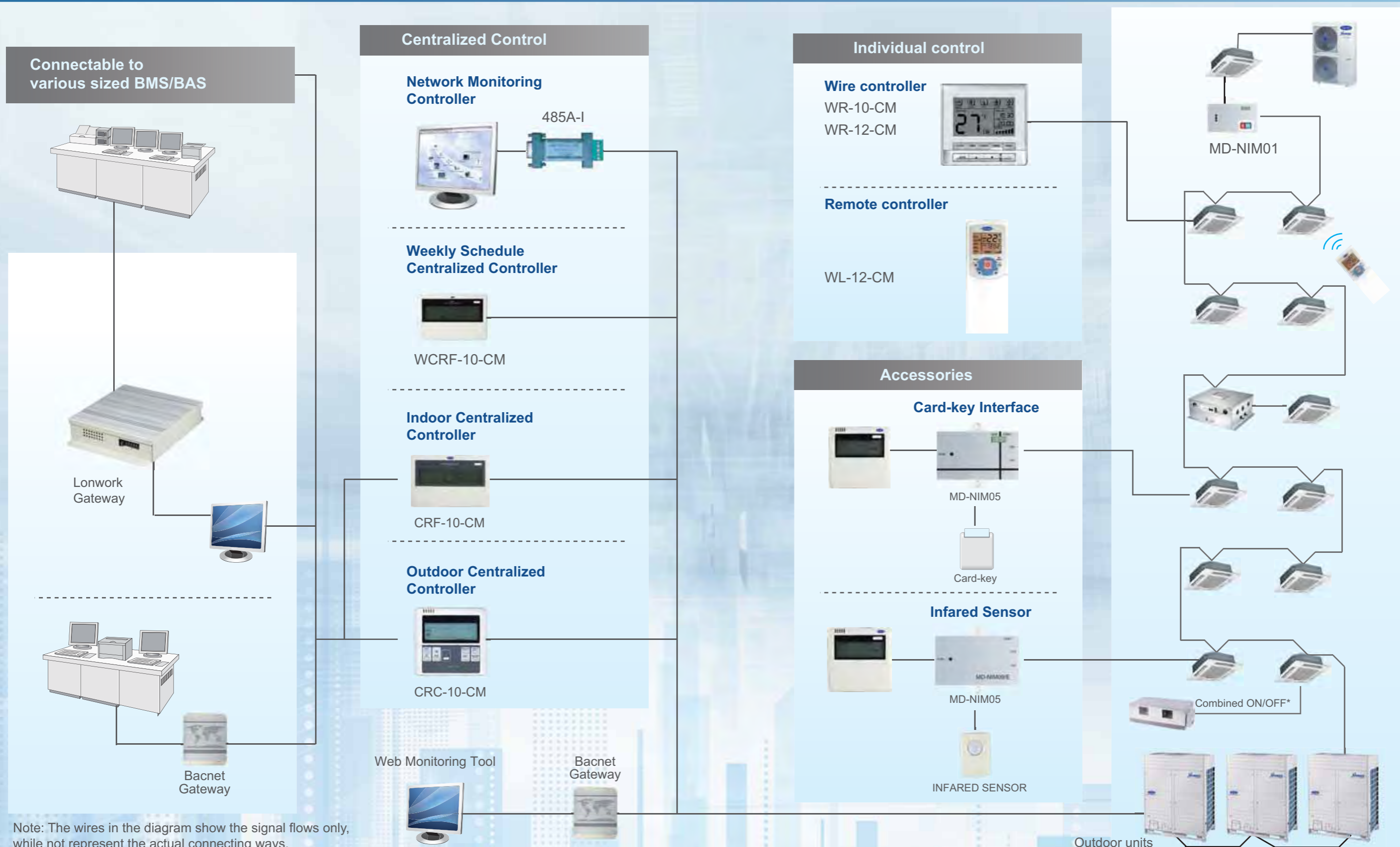

Note: The wires in the diagram show the signal flows only, while not represent the actual connecting ways.
 *Combined ON/OFF function can be customized from us.

Comparison of Controllers

Item	Remote	Wired Controller	Centralized Controller	4th-generation Monitoring System
Model name	WL-12-CM	WR-12-CM	CRF-10-CM WCRF-10-CM	3GNS-10-CM
MAX. controllable IDU	1	1	16/64	1024
AC control function	On/Off	●	●	●
	Operation mode setting	●	○	○
	Heating mode	○	○	●
	Fan speed setting	●	●	○
	Room temp. setting	●	●	○
	Vertical swing	●	●	○
	Horizontal swing	○	○	—
	Economic mode	○	○	—
	Group setting	—	—	●
	Key lock	○	○	○
Display	Backlight	○	○	●
	Current time	○	—	○
	RC prohibition	—	—	○
	Address	—	—	●
	Error code	—	—	○
Timer	Period	—	—	Week
	On/Off per day	—	—	4
	On/Off per week	—	—	28
	On/Off timer	●	●	○
Control	FOLLOW ME	○	○	—
	Emergent stop	—	—	○
	Emergent start	—	—	○
	Address setting	○	—	—
	BMS access	—	—	○
	Control via internet	—	—	○

- : Each of this kind of controller has the corresponding functions.
- : This function is optional.
- : This function is not available through the corresponding controller.

WIRED CONTROLLER

Wired Controller



Functions

Follow me

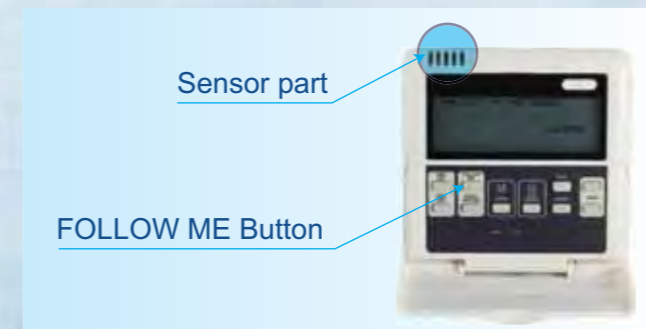

With the FOLLOW ME function, WR-12-CM the wired controller can detect the air temperature at the user's altitude instead that of the ceiling or the floor. This helps making the room environment comfortable and the temperature accurate.

Built-in timer

Built-in daily timer offers the convenience of automatically starting and turning down the air conditioners according to the set time.

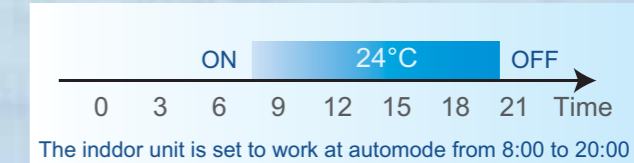

Easy connection

Wired controller conveniently connects to the indoor unit's display panel with the appropriate connecting wire.

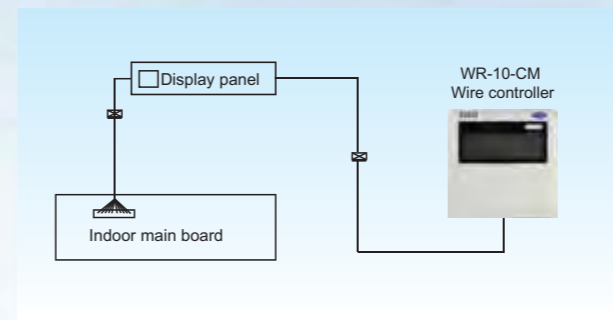

Easy installation

The wired controller allows to be installed into the wall by fixing the bottom directly or fixing the device to a mounting cabinet.

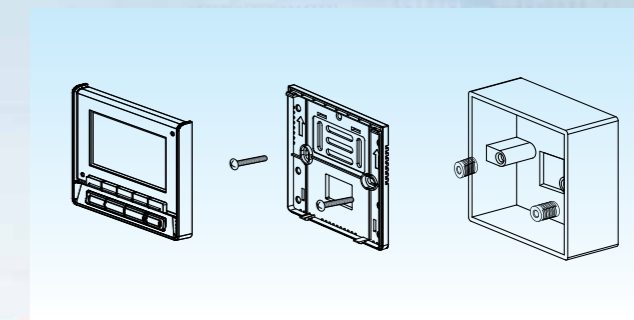

Model	WR-10-CM	WR-12-CM	WR-90-CM
Dimensions	120×120×15	120×120×15	90×86×13
Power	Power from the display panel. Extra power is unnecessary.		

CENTRALIZED CONTROLLER

INDOOR CENTRALIZED CONTROLLER

CRF-10-CM



front appearance

side appearance

Functions

Centralized control

CRF-10-CM is a multifunctional device which is able to control up to 64 indoor units. And the connection length can be up to 1,200m. With the newly designed machines, this device connects to the master outdoor unit, making the centralized wiring quite simple. The 2 ways of connecting is as follows:



Indoor unit working status display

CRF-10-CM displays both the indoor units working status and the error codes. Via checking the error codes table in the user manual, users can easily find out the malfunction and call the repairman.

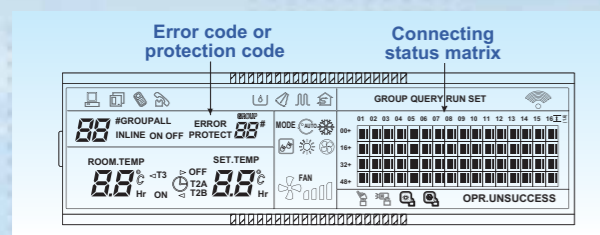

Access to network monitoring

CRF-10-CM is able to bridge up to 64 indoor units to the network monitoring system and the building management system.



Model	CRF-10-CM
Dimensions(H×W×D)(mm)	170×110×70
Power	198-242V(50/60Hz)

Three lock modes

Centralized controller CRF-10-CM provides a superior way to manage the indoor units. Users are able to make their own choice from locking the wireless controller, locking the running mode or lock the CRF-10-CM's keyboard, as they wish.

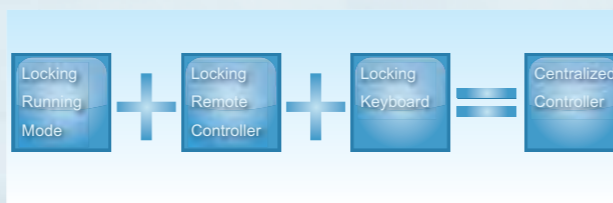

Single/unified control mode

The control object can be either single or all, making the controlling operation convenient and easy. With the operation signal feedback, users ensure their machines work at the precise working mode.

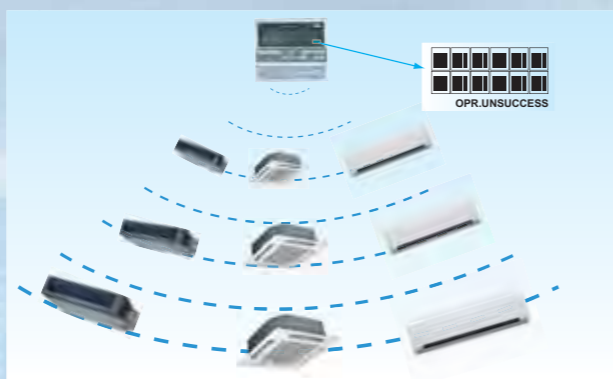

WEEKLY SCHEDULE CENTRALIZED CONTROLLER

WCRF-10-CM



front appearance

side appearance

Functions

Weekly schedule

WCRF-10-CM allows up to 64 indoor units making the weekly schedule. Users can set up to 4 periods per day and select the desired running mode and room temperature. The operating object could be any indoor unit or all the indoor units.

	8:00	16:00	23:59
Sun	28°C	22°C	24°C
Mon	26°C	22°C	23°C
Tue	26°C	17°C	23°C
Wed	26°C	17°C	23°C
Thu	26°C	22°C	26°C
Fri	26°C	22°C	26°C
Sat	28°C	off	24°C

Three lock modes

Centralized controller WCRF-10-CM provides a superior way to manage the indoor units. Users are able to make their own choice from locking the wireless controller, locking the running mode or lock the WCRF-10-CM's keyboard, as they wish.

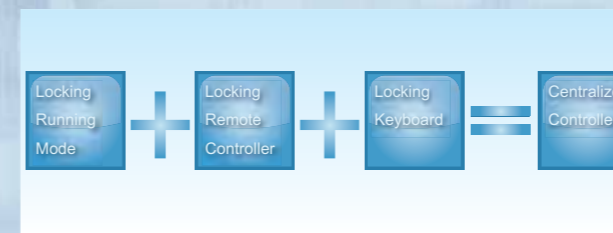

Single/unified control mode

The control object can be either single or all, making the controlling operation convenient and easy. With the operation signal feedback, users ensure their machines work at the precise working mode.

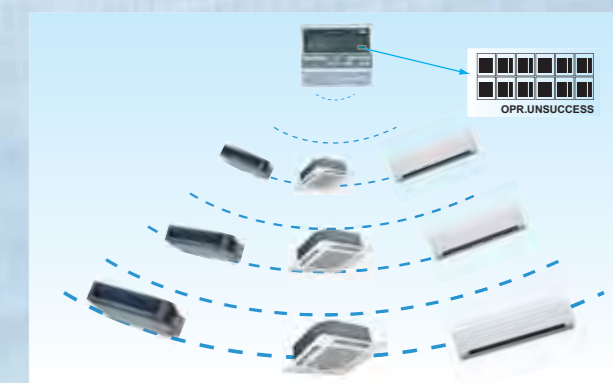

Indoor unit working status display

WCRF-10-CM displays both the indoor units working status and the error codes. Via checking the error codes table in the user manual, users can easily find out the malfunction and call the repairman.

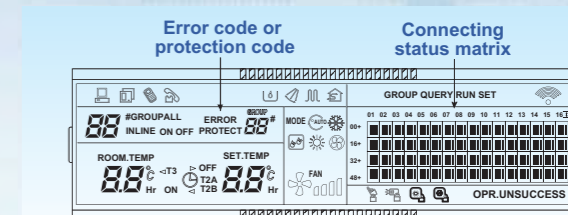

Model	WCRF-10-CM
Dimensions(H×W×D)(mm)	170×110×70
Power	198-242V(50/60Hz)

CENTRAL CONTROL SOFTWARE

4TH GENERATION MONITORING SYSTEM
4GNS-10-CM
4GNS-10-IF



Functions

Friendly user interface

4th generation monitoring system offers a simple and explicit user interface to allow realize its functions simply. 4th generations monitoring system is able to control up 1024 indoor units and 512 outdoor units.

Group definition 4th

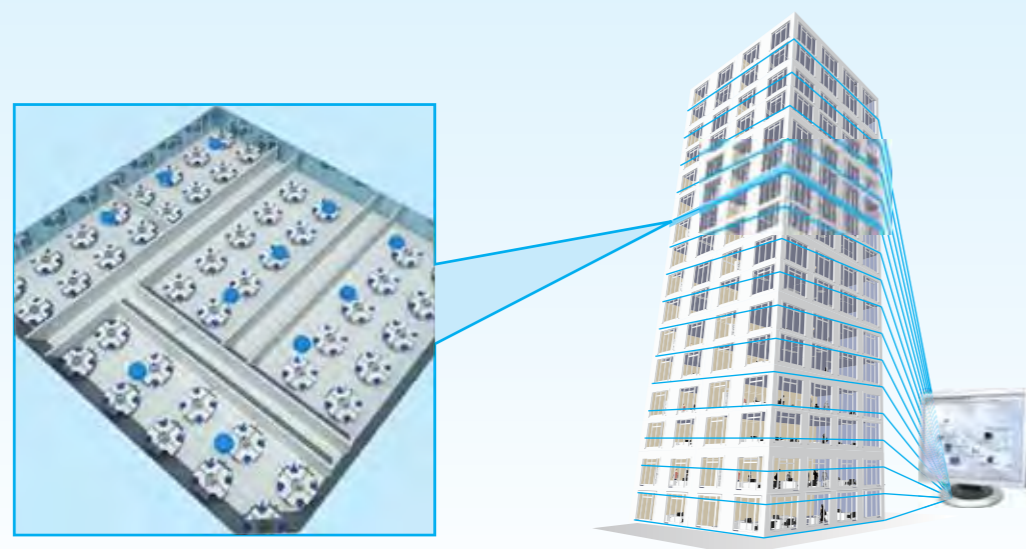
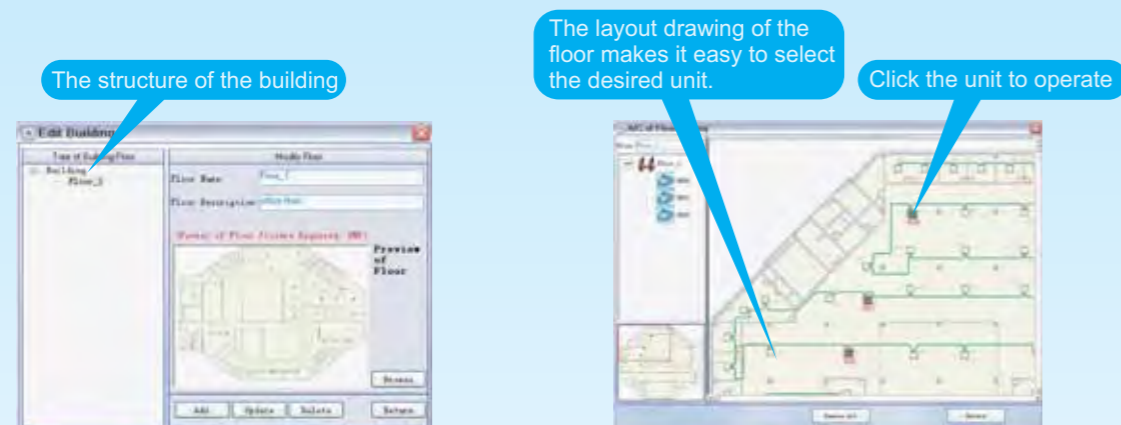

Multiple functions

4th generation system is able to realize the remote control of indoor units. The command of indoor unit can be both the normal ones, such as changing the running modes, adjusting the temp., timer functions, and the higher class command, such as excluding the other controllers to realize unique PC control.

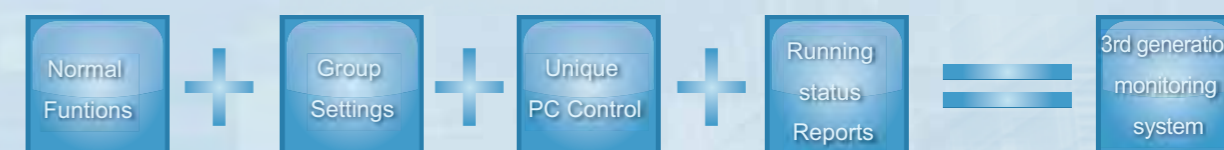

Running parameter display

4th generation system can synchronize both the indoor and outdoor units' running status and parameters, to realize the visual control of the refrigerant system. Moreover, the 4th generation system records the running status and error information of the refrigerant system, which helps the maintenance accurate and easy.



Electricity charge apportionment

With the appropriate devices, 4th generation system can record the total electricity consumption and the on/off time of the outdoor units. And with the indoor units' actual cooling power, the software intelligently distributes the power consumption to each indoor unit. Moreover, the software can generate the electricity charge bills and the bill of the indoor units' on/off time, which is a basis of the power consumption.

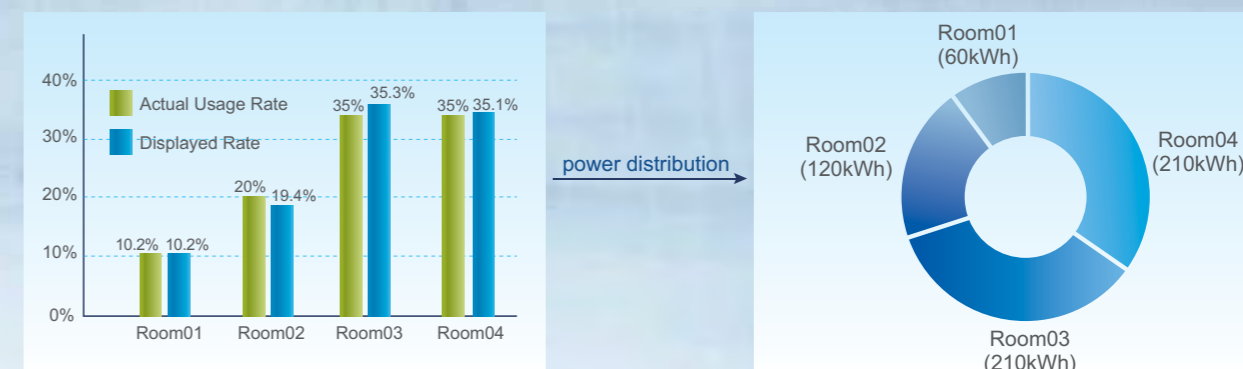

The principle of the electricity distribution



HOTEL CARD KEY INTERFACE MODULE HC-10-CM

Cooperate with the wired controller to realized humanistic automatic control. High voltage power is unnecessary, making the device safe and steady. Auto-restart function inside.



Installation example

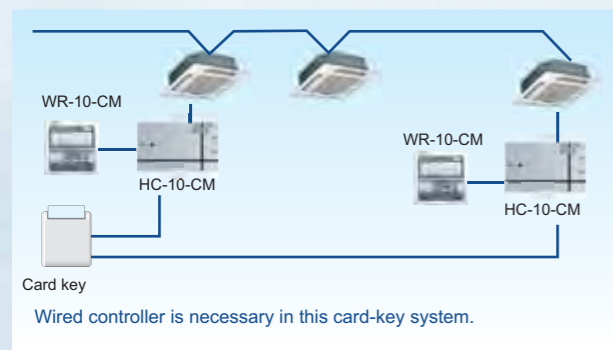

Electrical wiring

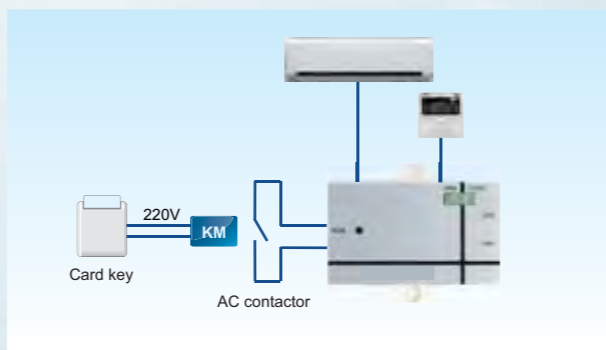

Model	HC-10-CM
Dimensions(H*W*D)(mm)	86*72.8*15.5
Power	Powered from display panel. Extra power unnecessary.

INFRARED SENSOR CONTROLLER HC-18-CM

Automatically adjust the room environment. Automatically extend the shutting down time, avoiding frequent ON/OFF. Graceful appearance accommodates itself to the different buildings.



Installation example

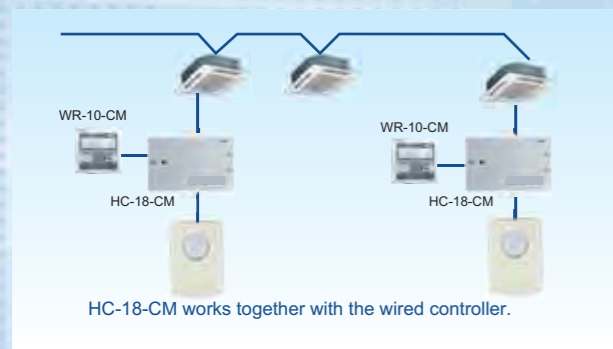

Electrical wiring

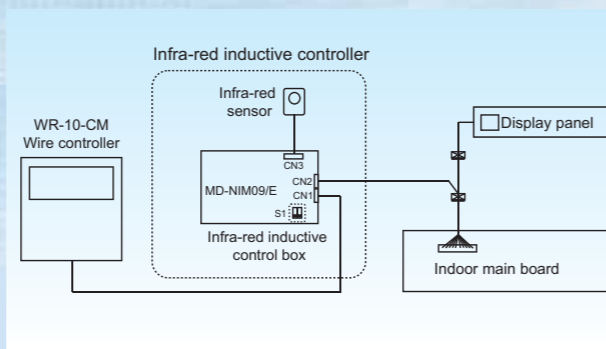

Model	HC-18-CM
Dimensions(H*W*D)(mm)	Senor part: 46*30*25.6, Control box: 86*72.8*15.5
Power	Powered from display panel. Extra power unnecessary.

3-PHASE PROTECTOR GMR-32B

Detect the power condition and make the corresponding protecting action. Protect the compressor from being damaged. Automatically distinguish the power supply's abnormal type and automatically recover.



Excellent reliability

The protector protects the entire system from power supply problems, Moreover, the protector can automatically recover from switching off status.

Multiple protections

■ GMR-32B protects the entire system from many kinds of power supply problems.

Protection	Type	Action Time	Action condition
Phase reverse		0.5S	
Dynamic/static phase loss		1S	
Over/under voltage	-	7S	Operating voltage is over setting voltage
	T	30S	
Phase imbalance		5S	Voltage deviation is over 10%
Fail-safe			Input power fails, relay does not act

Model	GMR-32B
Dimensions(H*W*D)(mm)	63*43*79
Power	200-500V(50/60Hz)

DIGITAL POWER METER DTS634/DTS636

Calculate the power consumption. Do not need adjustment after working for long periods. One outdoor unit corresponds one digital power meter.



Low power consumption

The digital power meter works at low consumption. The working power is as follows:

Voltage circuit: less than 2W/10VA
Current circuit: less than 2.5VA

Indications and installation

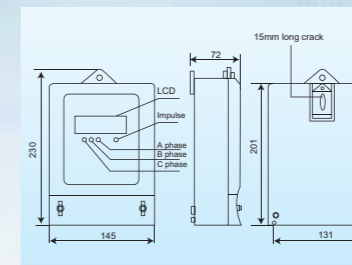

The digital power meter is checked to be up to standard after it is manufactured, so it's able to work at once on the project site. The lights indications and the installation are as the left.

Model	DTS634 / DTS636
Dimensions(H*W*D)(mm)	230*145*72
Power	200V-500V(50Hz)



SELECTION SOFTWARE

Carrier has developed a new program to design VRF systems which meets the consultants' and distributors' requirements. The software provides a quick and convenient selection for users, which supports multi-languages. Greatly improving the selection efficiency and simplifying the procedure.

Project

It contains project information such as project name, nation, location, etc. Detailed meteorologic datas make the machines selected fit for the local environment well.

A/C selection

There are 15 types and 100 models of indoor units and all kinds of different power of outdoor units for choosing.

Controller selection

To select the right central controller for indoor units and outdoor units; wireless or remote controller for indoor units.

Load calculation

It provides two calculation methods. Directly decide the room load or input the detailed parameters such as room area, estimated cooling/heating load index, heating capacity and cooling capacity.

Piping drawing





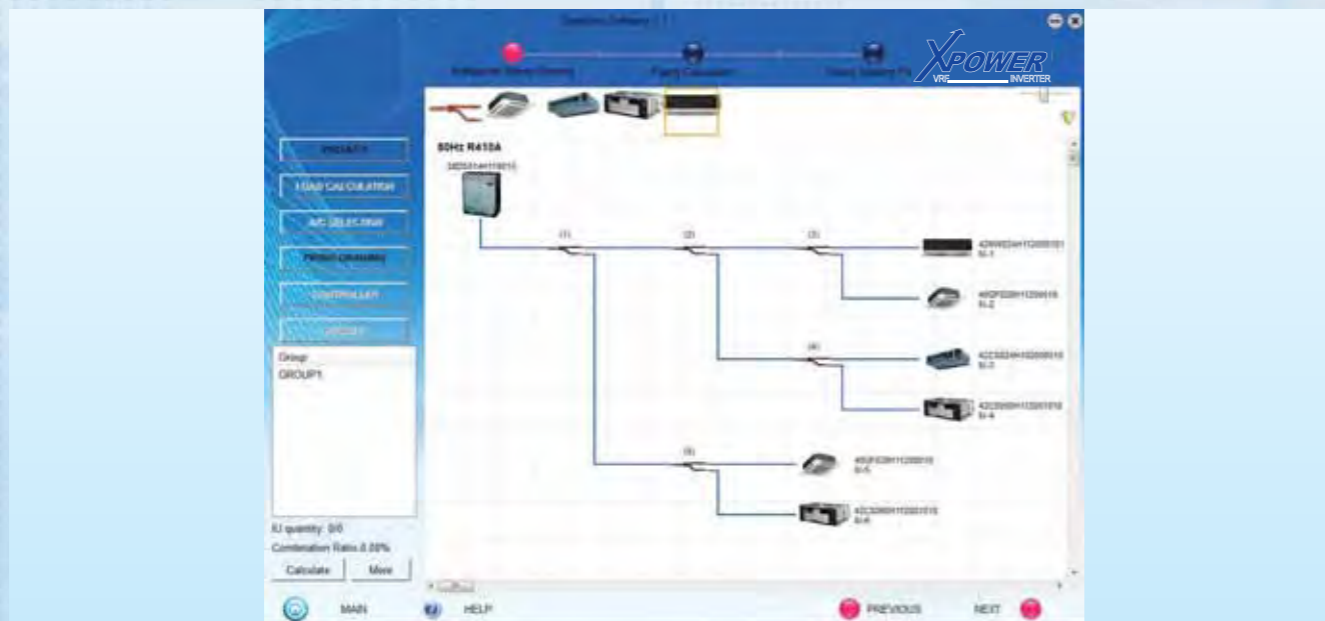

Piping drawing shows the detailed layout of an A/C system and parameters of piping and branch distributors.

Report output

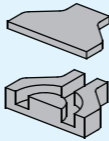
Output a total report of selection project in word or PDF format.

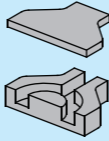

ACCESSORIES

Accessory	Shape	Model	Description
 Branch joint for outdoor unit		BJC-02-CM (i)	For two outdoor units combination at installation location
		BJC-03-CM (i)	For three outdoor units combination at installation location
		BJC-04-CM (i)	For four outdoor units combination at installation location
 Branch joint for indoor unit		BJF-224-CM (i)	$A^* < 16.6 \text{ kW}$
		BJF-330-CM (i)	$16.6 \leq A^* < 33 \text{ kW}$
		BJF-710-CM (i)	$33 \text{ kW} \leq A^* < 66 \text{ kW}$
		BJF-1344-CM (i)	$66 \text{ kW} \leq A^* < 92 \text{ kW}$
		BJF-E1344-CM (i)	$92 \text{ kW} \leq A^* < 180 \text{ kW}$
		BJF-1500-CM (i)	$180 \text{ kW} >$
Drain pump		SBH-01	
		SBH-03	For low/high static pressure duct type indoor
		SBH-04	unit(Optional)

Refrigerant Distributors

Branch list of indoor unit

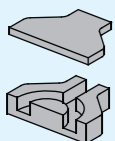
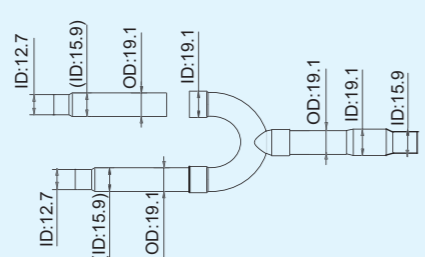
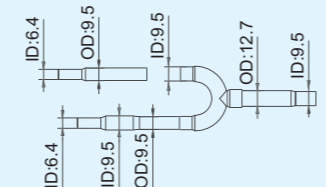
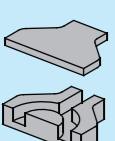
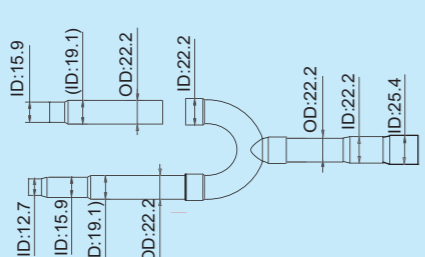
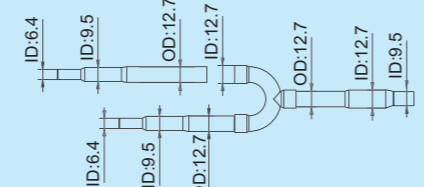
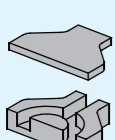
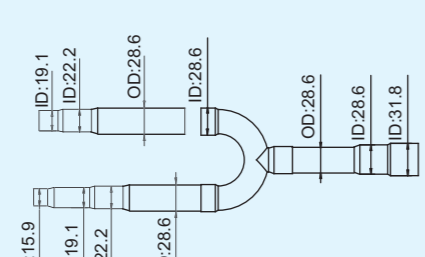
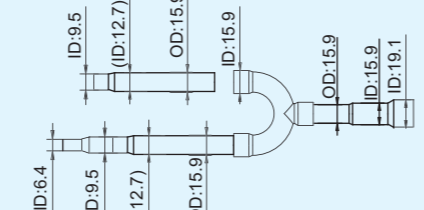
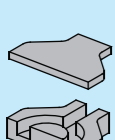
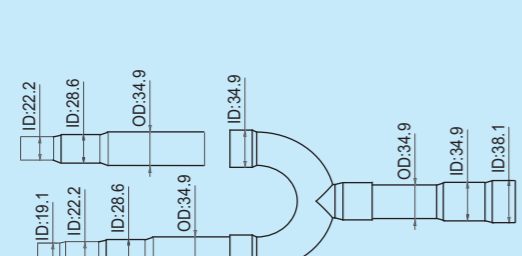
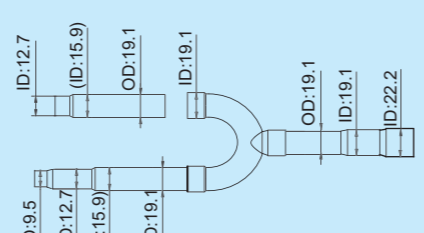
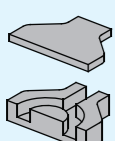
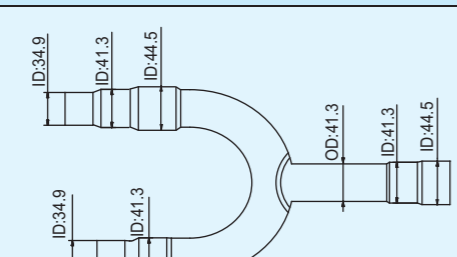
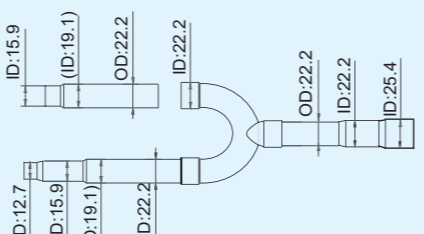
Name	Gas side joints	Liquid Side Joints
 BJF-224-CM		
 BJF-330-CM		
 BJF-710-CM		
 BJF-1344-CM		
 BJF-E1344-CM		

Branch list of outdoor unit

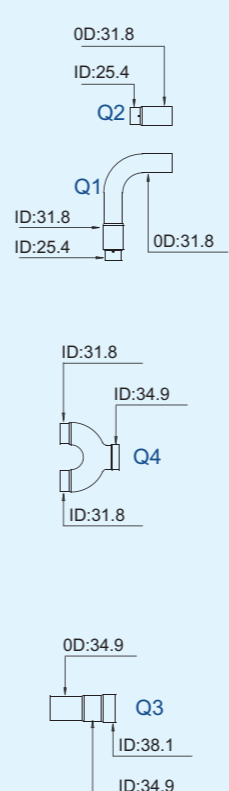
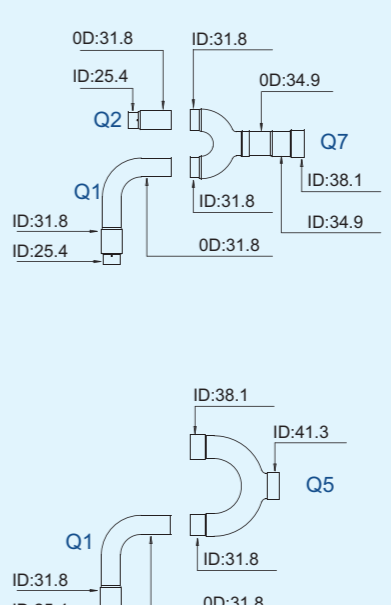
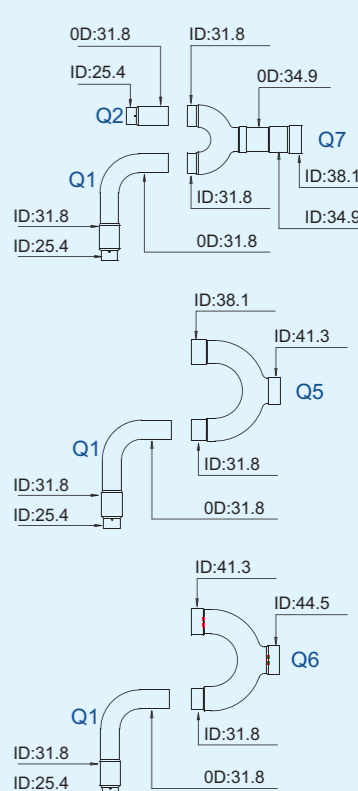
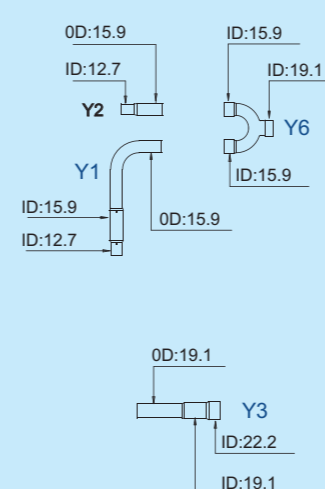
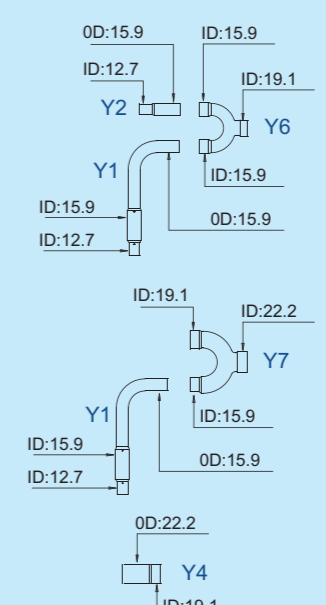
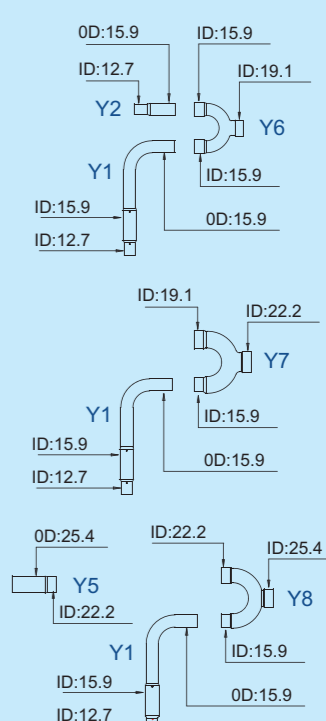
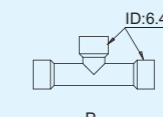
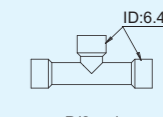
Outdoor branch	BJC-02-CM	BJC-03-CM	BJC-04-CM
Gas side			
Liquid side			
Oil balance pipe		 <p>P</p>	 <p>P(2pcs)</p>

